

PRO SFD

Instruction & Technical Manual

W WALKER
FILTRATION

ULTIMATE FILTRATION TECHNOLOGY

Walker Filtration Ltd, Spire Road, Glover East,
Washington, Tyne & Wear NE37 3ES ENGLAND

Table of Contents

	Page:
1. Introduction.....	3
2. Safety	4
3. Description of the dryer's main components.....	6
4. Explanation of the dryer's main components.....	7
5. Connecting the pre-filter to the dryer.....	8
6. Installation.....	9
7. Electrical supply	10
8. Energy management and PC interfacing	11
9. Operation	21
10. Start up.....	22
11. Service and fault diagnosis	23
12. Dryer troubleshooting	31
13. Dryer sizing table.....	33
14. Environmental conditions.....	35
15. Warranties and liabilities.....	36
16. EC Declaration of conformity	37

1. Introduction

The product to which this manual refers must not be supplied, installed, used, operated or serviced until the contents of the manual have been fully read and understood by all relevant personnel.

This manual, and in particular the safety information, should be kept at the place of installation of the product. All relevant personnel must strictly follow instructions given in the manual.

When contacting Walker Filtration regarding this product or manual, please have the following information available:

- Serial number:
- Date of commissioning:

The serial number can be found on the identification plate located on the rear panel of the unit and this information should be copied into this manual for future use.

The dryer is delivered in protective packaging. Take care when transporting, loading and unloading the unit.

The dryer is delivered configured specifically at the point of order. It is important to ensure that the correct plug is fitted applicable to the operating pressure. See table on page 38 for further information.

The dryer package includes:

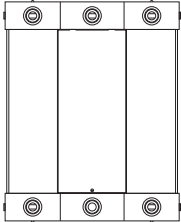
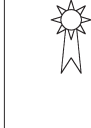
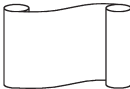
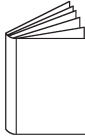
			
DRYER	WARRANTY	CERTIFICATE OF CONFORMITY	INSTRUCTION MANUAL

2. Safety

Walker Filtration explicitly excludes all responsibility and liability for damage and/or injury caused by failure to follow the instructions described in this manual, or by failing to pay necessary attention when operating handling or servicing this product, even if not specifically stated in individual cases.

The unit must be used for its intended purpose. The heatless-regenerating adsorption dryer is designed and manufactured exclusively for drying of compressed air within conditions as described in section 11 of this manual. Any other use of the unit will be considered inappropriate and Walker Filtration shall not be liable, where this is permitted under law, for any damage incurred as a result of misuse.

The following symbols give indication of potential hazard. Appropriate measures must be taken to reduce risk to any user or operator of the machine wherever such hazard exists.



Warning:
Risk of Danger

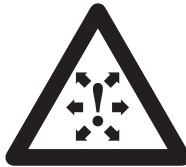

Caution:
Risk of High Pressure



Caution:
Risk of Electric Shock

The following safety guidelines must be strictly observed:

- Leave this manual at the place of installation of the product.
- It is essential that only Walker Filtration or their appointed agents carry out maintenance and servicing work.
- Users, maintenance and servicing personnel must be familiar with:
 - accident prevention regulations
 - safety information (general and specific to the unit)
 - safety devices of the unit
 - measures to be taken in case of emergency
- Allow only suitably trained persons to be involved with installation, start-up, operation, servicing and maintenance of the product.
- It is the responsibility of the installer to ensure that the pipe work to and from the dryer is suitable, in accordance with applicable legislation and subject to inspection and testing prior to being put into service. All piping must be adequately supported.
- Before carrying out any maintenance or servicing work the unit must be taken out of operation. Users and others will be exposed to risk if work is carried out whilst the unit is running. This means electrical disconnection plus isolation from the compressed air supply and full depressurisation.
- Only trained and competent persons familiar with the electrical requirements of the unit as laid out in this manual and electrical safety rules and regulations should be allowed to carry out work on the electrical components and power supply to the unit.
- When carrying out any work on the unit, use only correctly sized appropriate tools in good condition.
- Only use original spare parts and accessories from the manufacturer. There is no guarantee that non-original parts have been designed and manufactured to meeting the safety and operational requirements of the unit. Walker Filtration assume no liability for any equipment malfunction resulting from the use of non-approved parts.
- If carrying out installation work above head height, use suitable and safe working platforms or other means of working access.
- Do not make any constructional changes to the product. Any changes or modifications may only be carried out by the manufacturer, Walker Filtration.
- Any faults or defects that could affect safety must be put right fully before using the unit.
- Used items and materials must be disposed of in the correct manner, complying with local laws and regulations, in particular the desiccant cartridge.



3. Description of the dryer's main components

The figure below shows the main elements of a typical dryer.

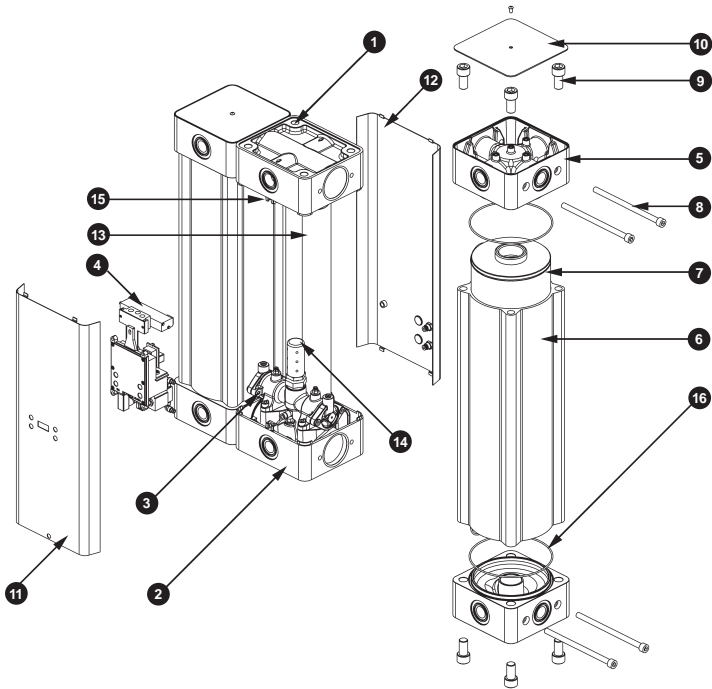

- | | | | |
|---|---|----|--------------------------------|
| 1 | Inlet valve assembly | 10 | Quadra-port manifold top cover |
| 2 | Bottom valve assembly | 11 | Front panel |
| 3 | Exhaust valve assembly | 12 | Back panel |
| 4 | Control/valve unit | 13 | Air transfer down-pipe |
| 5 | Quadra-port manifold | 14 | Silencer |
| 6 | Pressure housing | 15 | Purge plug |
| 7 | Desiccant cartridge c/w dust filter
(where applicable) | 16 | O-ring seal |
| 8 | Pressure housing retaining bolt | | |
| 9 | Quadra-port manifold retaining bolt | | |

4. Explanation of the dryer's main components

4.1 Control unit on page 6

The bottom valve block is operated by solenoids within the control unit that determine the pressure and direction of air flow into the desiccant cartridges, where applicable.

4.2 Desiccant cartridge c/w dust filter

The cartridges contain the agent (desiccant) that has been developed for the drying of compressed air. The desiccant is housed in a clear tube that has a holder permeable to air at both ends. Located in the top of each cartridge is a 1-micron filter for removal of residual dust from the desiccant. The length of the cartridge varies with the flow capacity of the dryer.

4.3 Pressure housing

The cartridges are contained within an extruded aluminium pressure housing and pressure retaining end plates. Process pressure and flow through each desiccant cartridge is controlled by means of top and bottom valve manifolds located between the two pressure housings. The regenerating air flow (purge) is controlled by means of a small orifice plug located externally on the bottom of the top valve manifold and is accessible with the front panel removed.

5. Connecting the pre-filter to the dryer

1. Fit lubricated 'o' ring between the filter and top valve manifold, observing the flow direction on both.
2. Fasten filter bolts evenly to 4 Nm.
3. Fit 4mm (5/32") black tubing to filter and drain valve inlet.
4. Pipe away condensate with 4mm (5/32") tubing from drain outlet. Ensure condensate is drained into an oil/water separator.
5. Fit any further filtration or ancillary equipment.

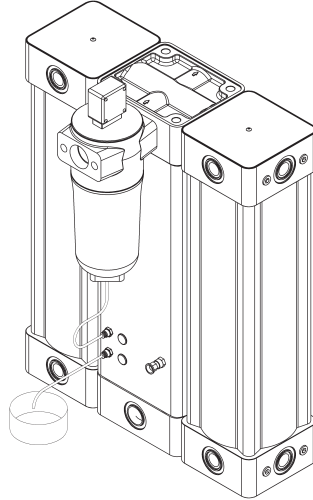

All tubing should be secured up to the point of drain to prevent whipping during discharge.

5.1 Recommendation

It is recommended that a bypass line including filter is installed.

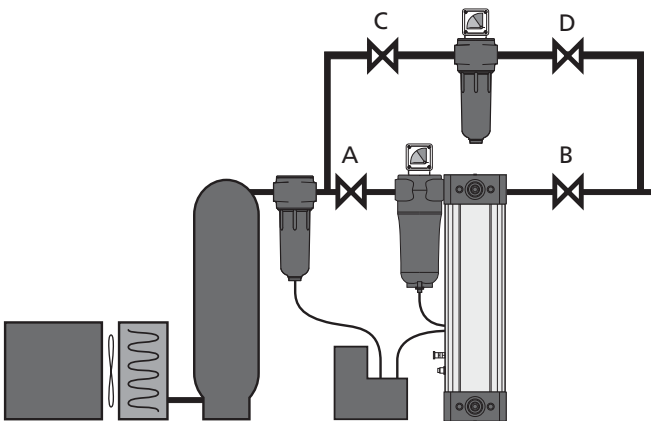
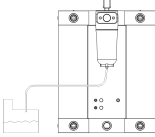
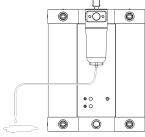
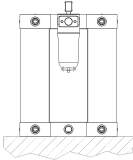
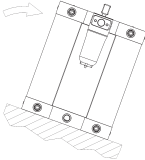
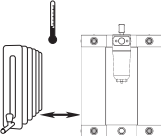
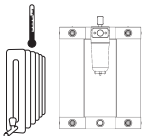
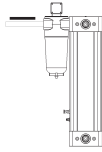
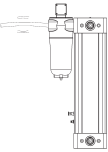
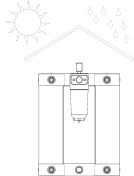
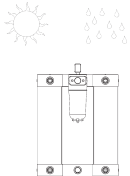
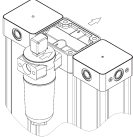
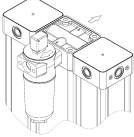

Figure 5.1

6. Installation requirements

Correct		Wrong	
< 35°C	> 35°C		
< 16 barg	< 4 barg		
> 12 V	< 12 V		
			
			
			



7. Electrical supply

7.1 Connection

1. The dryer is designed to operate on either an AC or DC supply voltage.

Ensure only one power source is connected at any one time, the power connection is factory fitted and must be specified at the point of order.

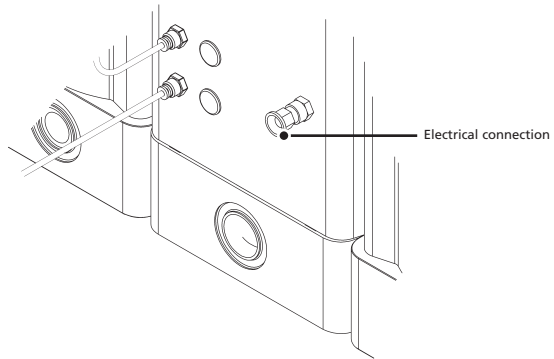

Figure 6.1

2. The dryer is double insulated therefore no earth is required.
3. Suitable external fuse connection must be provided.
4. The cable selection must suit local installation regulations and be appropriate to power consumption.

Supply	Amp
12 VDC	0.8
24 VDC	0.4
100 VAC	0.16
115 VAC	0.14
230 VAC	0.07
240 VAC	0.067



8. Energy management and PC interfacing

8.1 Interfacing the controller with a PC

8.1.1 Introduction to the software

The dryer controller has the ability to interface with a PC. This gives the user or the service engineer the opportunity to interrogate the dryer to check the following:

- Operating stage times
- Service warnings
- Operating history
- Alarm settings
- Fault history
- Fault and service history
- Real Time displays
- Setting Energy Management Parameters – contact Walker Filtration for details



Connecting the PC to the controller

8.1.2 PC requirements

Controller Application software: Windows 95, Windows 98, Windows 2000, Windows ME & Windows XP.

8.1.3 Installing the application software

Simply load the CD into the PC and the software will automatically load-up and complete installation.

The Walker Filtration icon will be visible on the desktop.

8.1.4 Connecting the PC to the controller

Ensure that power to controller is isolated

Access to the controller is by removing the screw on the front panel, and removing the panel.

Using the lead supplied connect the serial port connector to the PC.

The RS232 connector is located on the underside of the controller.

Remove the blanking plug taking care not to lose it and connect the RS232 connector with the latch to the front of the dryer.

Controller shown in the inverted position for reasons of clarity

1. Condensate solenoid valve
2. Tower control solenoid valve
3. AC&DC supply DIN connections
4. Energy management DIN connection
5. Controller clear LED cover
6. RS232 Software connection
7. Alarm DIN connection

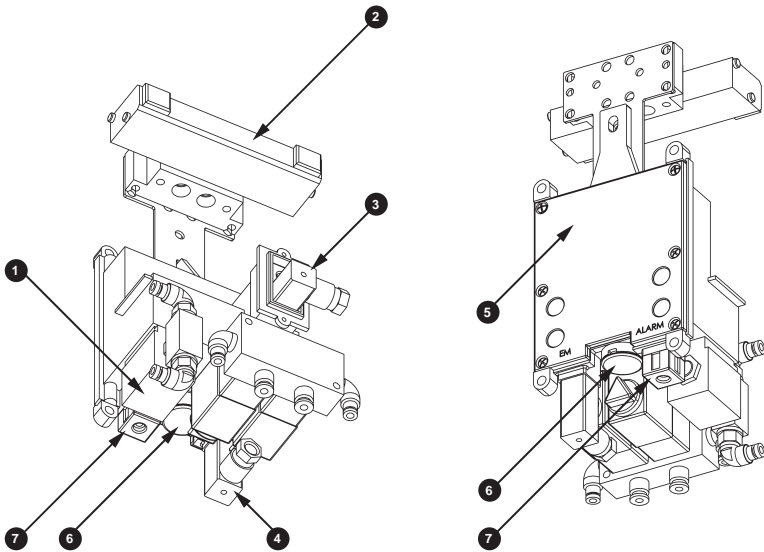

8.1.5 Starting the program

If not already connected, connect the RS232 serial link cable between the controller and the host PC.

Switch the power to the controller on. Launch the dryer application software by either double clicking the Walker Filtration icon found on the PC desktop or by clicking:

Start > Programs > Walker Filtration > Dryer Application Software

The first time the software is used the following window will appear.

Choose your preferred language by clicking the appropriate flag.

With the power to the dryer switched on the lead connecting the controller to the PC, double click the Walker Filtration CD icon on the screen.

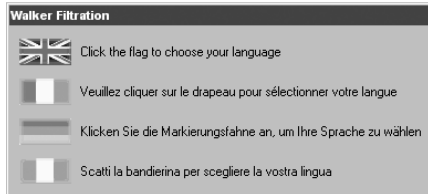

This will display the screen below, if the language is not as you require it then click the appropriate national flag and the next time the application software starts the language will be in the requested language.

1. Establish communication

Click the “Establish Communication” switch on the screen this will look for the link between the PC and the dryer controller.

The serial number on the software must match the serial number on the controller to allow communications to be established.

If communication cannot be made, a warning will appear at the bottom of the screen.

This may be due to the following:

- Poor connections to the controller
- Controller switched off
- Application software/controller serial number mismatch

Once communication has been established, click the “Read dryer” button on the screen this will then display the default setting from the works or the last setting the Service Engineer made.

It is possible to change some of the controller settings from the factory default settings on the screen. This should only be done by a qualified service engineer.

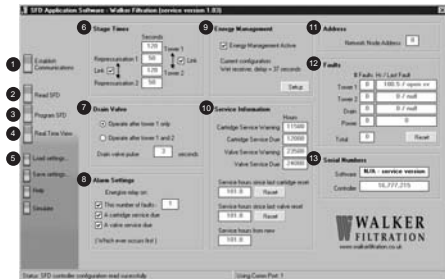



8.1.6 Programming dryer

Once it has been decided to change the default settings, and communications have been established and the dryer existing valves read the procedure for change is:

- Click into the box you wish to change.
- Over write with the items you require (note stage times are in 10 second intervals).
- Click "Program dryer" (a warning will appear asking to confirm the change).
- Click to confirm and this will change operating parameter.
- Click in real time to check set up.

2. Read dryer

Reads the current settings of the controller

3. Program dryer

Programs the controller with the new settings

4. Real Time view

This screen can be opened by clicking the real time screen. In addition to the main display panel shown previously there is also a real time view, which illustrates the operation of the dryer valves as it happens. It also counts down the remaining time to run on the valve operation. This is useful in confirming faults, which are displayed with the LED's on the front display panel.

To view the status of the controller in real time, click the 'real time' view switch. A new window will appear animating the dryer controller status in real time.

The following information is shown:

- The stage the controller is in through its cycle, including remaining time on the particular stage.
- Valve conditions
- Power condition
- Cartridge and valve service conditions
- Energy management condition
- Alarm condition

5. Load settings

Allow previously stored settings to be loaded into the controller

6. Stage times

- Tower 1 & Tower 2 – Indicates the time that a tower is depressurised.
- Re-pressurization – Indicates the re-pressurization time set on the controller.
- Link – Enables or disables the tower 1 & tower 2 settings to be linked.

7. Drain valve

- Operate drain operation toggle - Allows the drain to operation to be toggled to function after both towers or only one tower.
- Operate operation time- Sets the drain operation time.

8. Alarm settings

Allows the service Engineer to toggle and adjust the remote alarm activation values from the default values.

9. Energy management

Allows the user to set application parameters to save energy during periods of low demand.

10. Service information

Indicates the default settings at which the cartridge and valve service indicators will illuminate. The service history of the machine is logged, giving total hours run and hours run since the last service. Service re-sets provides an alternative method of resetting service hours than using the re-set disc after a service has been carried out.

11. Address

Indicates the network address for networked dryers.

12. Faults

The first column indicates the number of faults up to 50 every 30 minutes. The second column indicates the type of fault and the hour it occurred from now.

13. Serial number

Indicates software & dryer serial number to ensure they correspond.

8.1.7 Remote fault alarm

A remote alarm relay is built into the controller to facilitate an alarm connection remote from the dryer. This can activate at the service due period or with a pre-defined number of electrical faults or both.

This can be enabled or disabled using the software interface. The alarm requires a power source to be brought to the controller and on activation the controller will switch on in an alarm condition. This in turn can be used to activate a remote audible or visual indicator.

8.2 Energy management feature (EM)

8.2.1 Description

The purpose of the energy management feature is to save energy by reducing compressed air consumption during periods of low demand by interrupting the normal purge cycle. This can be activated with a link from the receiver upper and lower pressure switches normally fitted to receivers.

In the case where the compressor is a continually running type or the dryer is remote from the receiver then a dew point dependent switch can be used to activate the energy management feature.

As standard, the energy management feature is supplied activated on all controllers. When connected to an external switching system, the energy management process will become operational. For systems where energy management will not be required, a jumper link is fitted to the supplied DIN plug.

8.2.2 Energy management connection

1. Remove DIN plug from EM connection on controller.
2. Remove blanking plug from cable entry nut on DIN plug.
3. Remove fixing screw and gasket from DIN plug body.
4. Separate DIN plug body internal from cover.
5. Remove jumper wire from pins 1 & 2 on DIN plug body internal.
6. Connect external switching device cable to pins 1 & 2 on DIN plug body internal, ensuring that cable entry nut, washer and seal are in place.
7. Assemble DIN plug body internal into cover and reconnect DIN plug to EM connection on controller, ensuring that screw and gasket are fitted.
8. The controller gives a +5VDC from pin 1 on the EM DIN. Operation of the EM feature is by opening and closing the circuit.
9. Opening the circuit with an appropriate external relay or switch will activate the EM feature.

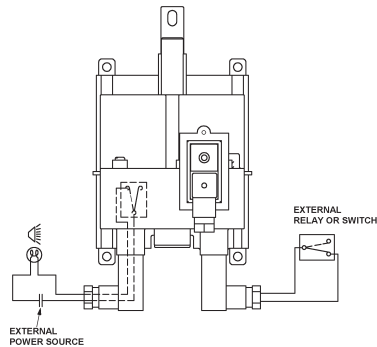

The user must ensure that the EM DIN plug as supplied with jumper wire, or an external switching arrangement is in place before the dryer becomes operational.



Ensure the energy management switching arrangement is in place before activating the EM facility and flowing air through the dryer.

8.2.3 Energy management application selection

For correct energy management operation it is important to select the correct mode of operation for the application.

For applications where the compressor, receiver and the dryer are in the same location linking the controller energy management into the compressor pressure limit switch, an effective method of energy saving is offered.

For applications where the compressor is a continual operating type or the dryer is point of use or is remote from the receiver, then a dew point dependant method of switching should be employed.

This links the operation of the energy management to the outlet dew point from the dryer.

The flow diagram below illustrates the correct selection:

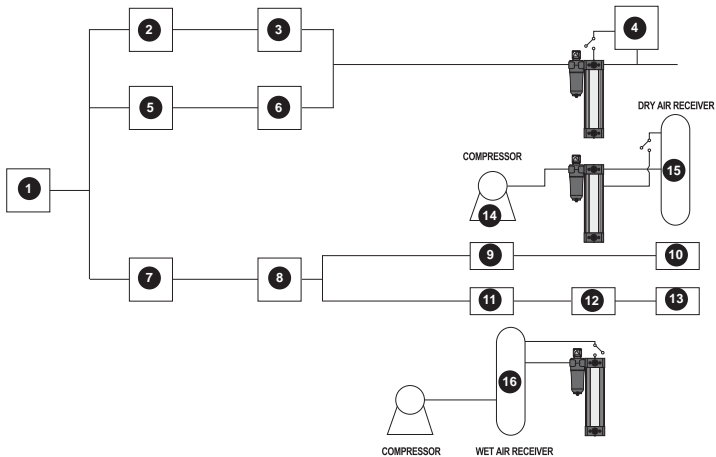

- | | | |
|---|---|---|
| 1 Energy management required | 6 Dewpoint dependant energy management switching | 11 Wet receiver application |
| 2 Point of use dryer application (remote from compressor) | 7 Dryer directly connected to local compressor and receiver | 12 Input compressor/receiver operating parameters |
| 3 Dewpoint dependant energy management switching | 8 Compressor load energy management switching | 13 Calculated EM delay |
| 4 Dewpoint monitoring | 9 Dry receiver application | 14 Compressor |
| 5 Continuous running compressor | 10 15 second default EM delay | 15 Dry air receiver |
| | | 16 Wet air receiver |

8.2.4 Connecting the PC to the controller

See 8.1 for connection of the PC to the controller. The energy management active box will be ticked and a default delay of 15 seconds operational. If this figure is considered suitable for the application, no further set up is necessary. If the application requires dedicated settings to be entered, follow the rest of the instructions in this section.

The energy management feature can be deactivated by unticking the box if necessary. Alternatively, the DIN plug with jumper link will override the energy management feature providing it is left in place.

Select dry or wet receiver from the illustration given in the set-up screen by toggling in the appropriate box.

Note: for point of use dryers or constant running dryers utilizing dewpoint monitoring the dry receiver system should be activated regardless of installation.

By switching “dryer receiver” this will operate the energy management facility after a 15 seconds delay.

For wet receiver applications switch the wet receiver box. To calculate the necessary delay it is necessary for the installer to input the high and low pressure set points for the compressor switch, the internal volume of the receiver and the flow rate of the dryer. The purpose of the delay is to prevent dryer saturation when using a large receiver with large range of set pressures.

Once the application conditions have been input click “OK” this will return the screen to main application software click “Program Dryer” will set and fix the previously defined conditions.

The RS232 connection can be removed by using a small screw driver to depress the retaining tang on the connector and withdrawn. Replace the push-in cover and replace the front panel.

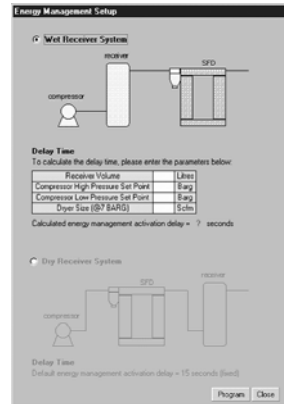

8.2.5 Energy management memory retention

Energy savings are made in the dryer by interrupting the normal purge operation during periods of low demand.

To maintain the equilibrium of the dryer towers the dryer has a memory retention feature. This allows the dryer to remember the point in the operating cycle when the energy management feature was activated and return to it to complete the cycle.

8.2.6 From new or service delay

To allow conditioning of the dryer desiccant beds to the optimum condition, a 6-hour delay has been programmed into the controller to delay Energy Management operation from new or from a service. Once this time has elapsed and the energy management facility can then be operated.

8.3 Alarm connection details

To enable the alarm facility it is recommended that a suitable cable is brought into the controller via the rear panel with a grommet. An external power source is required.:

1. Connect the switching pole of an externally powered alarm device to terminals 1 and 2 of alarm DIN connector.
2. With the power removed from the dryer and the alarm lead wired as described in 1 above, remove the cover from the DIN connection marked 'Alarm' and connect the wired DIN connector ensuring the seal and screw are fitted.

Alarm relay rating	3 Amp Max 28 VDC
Alarm connection type	Hirschmann GDS 207 industrial standard DIN connector or equivalent

8.4 Schematic wiring and fault diagrams

8.4.1 General wiring diagram

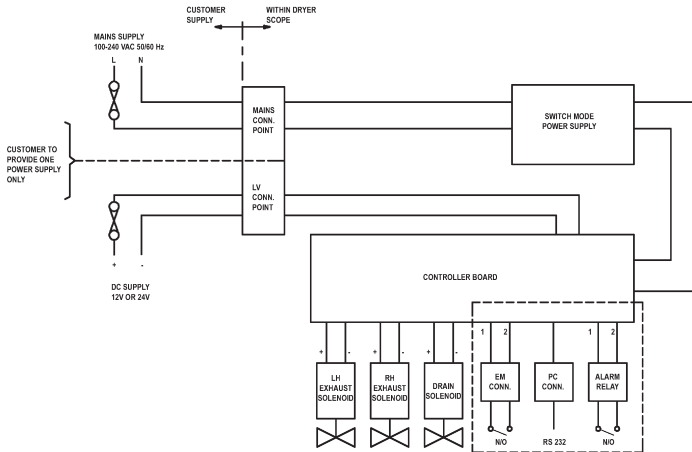

8.4.2 Remote alarm wiring diagram

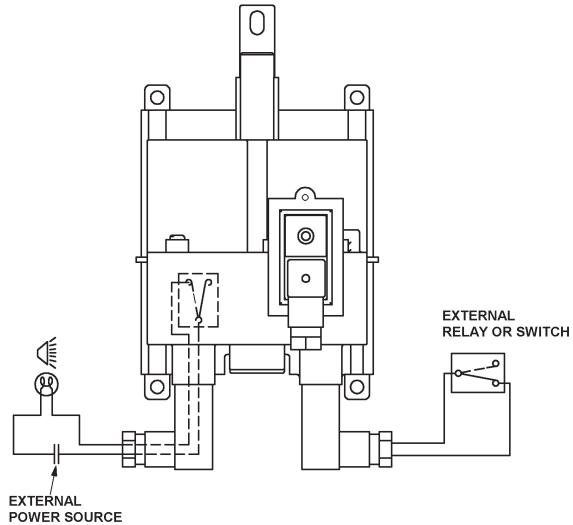

9. Operation

The dryer operation is designed to give smooth, uninterrupted delivery of compressed air to the designated specification.

During the cycle of operation, the first pressure housing is fully pressurized and airflow is directed upwards through the desiccant cartridge, removing moisture from the air during its passage, to the minimum specified dewpoint.

During the drying cycle, a small bleed of dry air (purge) is directed to the opposite pressure housing. This purge air flows down through the desiccant cartridge and to atmosphere by means of an exhaust silencer, thereby effecting regeneration of the desiccant.

After 120 seconds of operation, the cartridge under regeneration is sealed by closing of the exhaust valve and the pressure housing is brought up to full system pressure by the purge air.

After 170 seconds, the pressure in the first housing is released to atmosphere by means of the corresponding exhaust valve and the desiccant cartridge then operates in regeneration mode. The main air flow and drying function is then transferred to the desiccant cartridge that was previously under regeneration.

The cycle of operation continues in this pattern with the cartridges switching alternately between drying and regenerating.

10. Start up

10.1 Procedure

1. Close valves A, B, C and D.
2. Switch on compressor.
3. Open valve A slowly.
4. Check there are no leaks from the dryer.
5. Switch on electric power. All four display panel LED's will flash simultaneously green four times then simultaneously red four times to acknowledge application of power and readiness to function. Observe display panel for one complete cycle. Note: cycle described is factory setting.

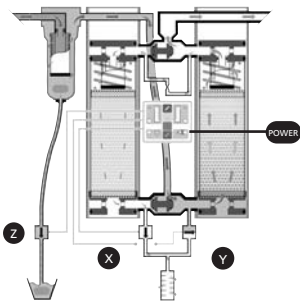
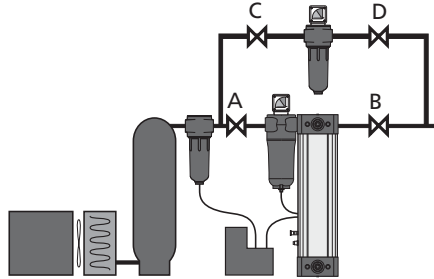

Figure 7.2. Dryer in operation

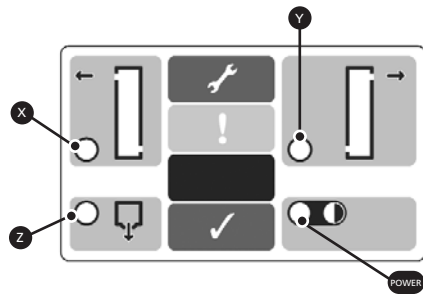
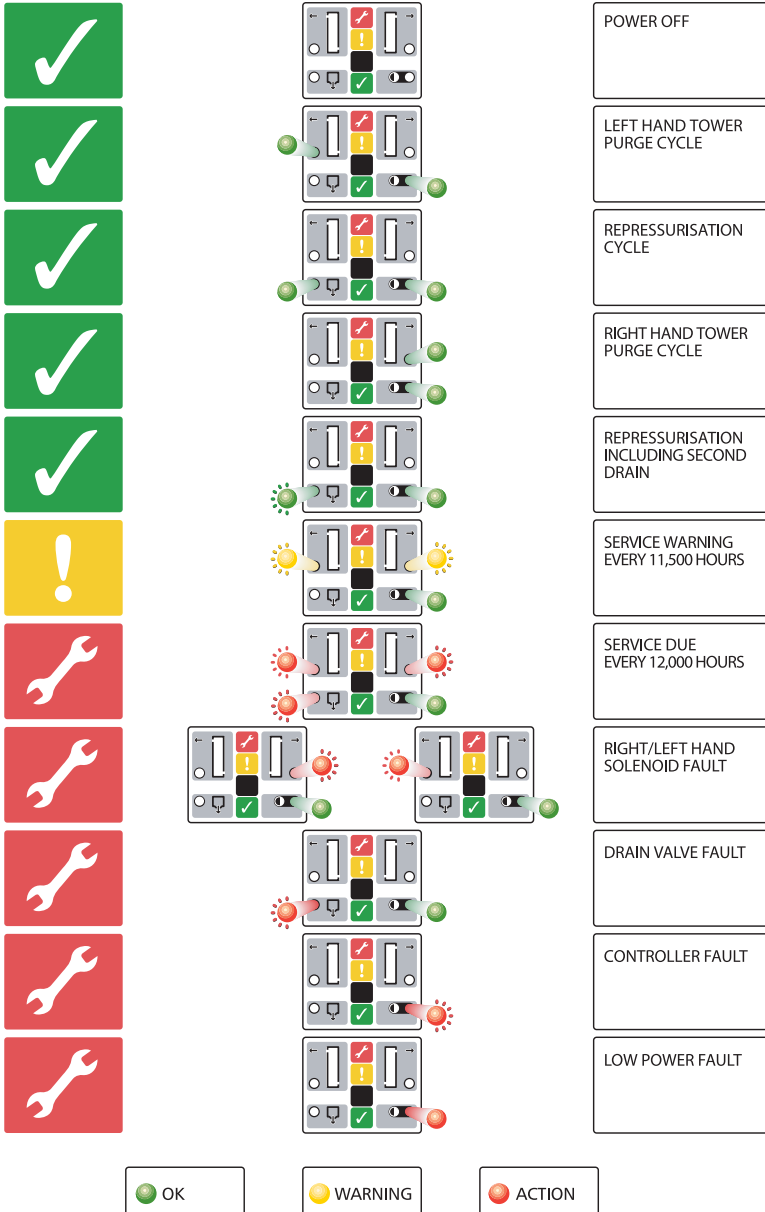

Figure 7.3. Display panel

- (i) Power LED illuminates green and tower LED X illuminates green.
- (ii) After 120 seconds, tower LED X switches off and drain LED Z illuminates green.
- (iii) After a further 50 seconds drain LED Z switches off and tower LED Y illuminates green.
- (iv) After a further 120 seconds, tower LED Y switches off
- (v) After a further 50 seconds, tower LED X illuminates green - this is (i) in the cycle described above.
- (vi) The above cycle (i-iv) repeats.
- (vii) Run the dryer for a minimum of 6 hours to ensure dewpoint is adequate.
- (viii) Open valve B slowly.

11. Service and fault diagnosis



11.1 Service shutdown

1. Close valve B
2. Close valve A
3. Leave dryer running for 15 minutes to fully de-pressurise
4. Switch off all electrical power to the dryer

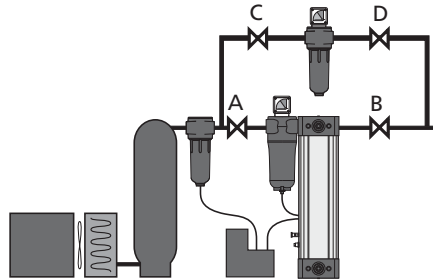

Under no circumstances must compressed air be allowed to flow through the dryer following switch off of electrical power. This will result in terminal failure of the desiccant cartridges and regeneration will not be possible.

11.2 Servicing and maintenance

1. Service intervals are every 12,000 operational hours. See chart below.
2. The shutdown procedure (above) must be carried out before a service is carried out.
3. The following kits are available.

Kit A: 12,000 hour service kit
Desiccant cartridges (where applicable)
Pre-filter element (where applicable)
O-rings and seals
Re-set disc
Instruction leaflet

Kit B: 24,000 hour service kit contains
Desiccant cartridges (where applicable)
Pre-filter element (where applicable)
O-rings and seals
Re-set disc
Exhaust valve solenoids (controller)
Exhaust Shuttles
O-rings and seals
Instruction leaflet

11.3 The service intervals and the kits required are detailed below.

2 years or 12,000 hours	Kit A
4 years or 24,000 hours	Kit B
6 years or 36,000 hours	Kit A
8 years or 48,000 hours	Kit B
10 years or 60,000 hours	Recommended service overhaul. Please contact Walker Filtration.



11.5 Removing and replacing the front panel



1. Dryer with front facia panel fitted.



4. Dryer with front facia panel removed.



2. Remove single retaining screw.



5. Re-fit front facia panel by insertion of tongue into groove and pushing upwards and inwards.



3. Remove front facia panel by tilting outwards and downwards.



6. Replace single retaining screw.



11.6 Purge plug removal



1. Remove front panel of dryer as described in 11.5 and locate purge plug in between the two bonnets.



4. Orifice in purge plug can be cleaned with warm soapy water. Do not use sharp implements or tools.



2. Remove bonnet fixing screws from upper valve block. Remove bonnet from valve manifold block.



5. After thoroughly drying the purge plug, ensure that 'O' rings are in place and in good condition. Locate between the bonnets.



3. Remove purge plug from port in bonnet downwards. This will allow the purge plug to be removed.



6. Replace and tighten bonnets.



11.7 Cleaning the silencer



1. Disconnect silencer from valve block.

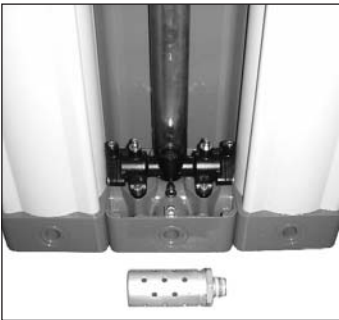

2. Silencer can be thoroughly cleaned in warm soapy water. Do not use sharp instruments or tools. Clean threads on silencer.

3. Ensure silencer is thoroughly clean and dry then replace by following the above procedure in reverse.



11.8 Replacing the exhaust valve assembly and exhaust shuttles



1. Remove front panel of dryer as described in 11.5.



4. Remove end bonnets, retrieving the O-ring.



2. Remove the capscrews securing the manifold in position.



5. Remove the exhaust shuttle.



3. Remove the manifold, taking care to retrieve the inter face O-rings. The silencer can be removed for maintenance if required.



6. Place the shuttle into the bore. Gently fold the seal into the bore whilst keeping pressure on the end of the shuttle. Refit the end bonnet. The refitting of the manifold is the reverse of removal.



11.9 Resetting the controller

1. After following the start up procedure it is necessary to reset the controller. This is done by using the re-set disc (supplied with 12,000 hour service kit) then:
2. Hold the disc against the blue pad on the front display of the dryer panel for 5 seconds.
3. During the five second period the power indicator D will flash green. When the reset has been successful indicator B will flash red once to confirm that it has been completed successfully.

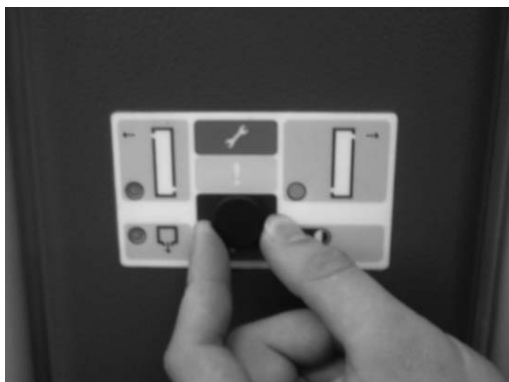

12. Dryer Troubleshooting

12.1 General troubleshooting



Before specific identification of any fault is looked for, the following general points must be verified:



- Has the unit been damaged externally or are any parts missing?
- Is power being supplied to the unit?
- Was startup carried out in accordance with the instructions in this manual?
- Are all external valves correctly set for operation?
- Do the operational conditions meet those specified at time of ordering and used for product selection?

The table below gives possible causes and corrective actions to faults that may occur on the dryer:

Problem	Possible cause	Action
Poor dewpoint	Liquid water at dryer inlet	Check pre-filtration and drains
	Excessive flow	Check actual flow against maximum specified
	Low inlet pressure	Check against specification
	High inlet temperature	Check against specification
	Silencer blocked or damaged	Replace silencer
Incorrect dryer operation	Air leaks	Tighten joints or fit new seals
	Jammed shuttle valves or faulted electrical components	See electrical operation trouble shooting section

Figure 9.1: General Troubleshooting Guide

12.2 Electrical troubleshooting (see display panel diagram in Section 11, page 26)

Problem	Possible cause	Display	Priority	Location	Action
No dryer function	No power supply	None			Check supply
Incorrect dryer operation	Left solenoid open or short circuit	Flashing red	P1	X LED	Replace solenoid valve
	Right solenoid open or short circuit	Flashing red	P1	Y LED	Replace solenoid valve
	Controller fault	Flashing red	P2	Power LED	Replace controller
	Lower power fault	Continuous red	P1	Power LED	Check supply
Drain not operating	Energy management active	None			Check installation
	Drain solenoid open or short circuit	Flashing red	P1	Z LED	Replace solenoid valve
	Controller fault	Flashing red	P2	Power LED	Replace controller

13. Dryer Sizing Table

DRYER MODEL	PIPE SIZE	INLET FLOW RATE			DRYER CONFIGURATION	DIMENSION mm			DIMENSION inch		
		Nm ³ /h	SCFM	L/min		A	B	C	A	B	C
PD035	3/4"	60	35	991	SIMPLEX	552	520	164	21.7	20.5	6.5
PD045	3/4"	76	45	1274	SIMPLEX	652	520	164	25.7	20.5	6.5
PD055	3/4"	93	55	1557	SIMPLEX	752	520	164	29.6	20.5	6.5
PD065	3/4"	110	65	1841	SIMPLEX	852	520	164	33.5	20.5	6.5
PD085	1"	144	85	2407	SIMPLEX	1052	520	164	41.4	20.5	6.5
PD105	1"	178	105	2973	SIMPLEX	1362	520	164	53.6	20.5	6.5
PD135	1-1/4"	229	135	3823	SIMPLEX	1562	520	164	61.5	20.5	6.5
PD175	1-1/4"	297	175	4955	SIMPLEX	1962	520	164	77.2	20.5	6.5
PD215	1-1/2"	365	215	6088	DUPLEX	1362	520	328	53.6	20.5	12.9
PD275	1-1/2"	467	275	7787	DUPLEX	1562	520	328	61.5	20.5	12.9
PD365	1-1/2"	620	365	10336	DUPLEX	1962	520	328	77.2	20.5	12.9

Note: The temperature and pressure correction factors (below) should be applied to the above flow rates to suit the application and ensure dryer performance. All flow rates are based on 7.0 barg (100 psig) and 35°C (95°F) at the dryer inlet.

SPECIFICATION	
Standard pressure dewpoint	-40°C (-40°F) -70°C (-100°F) with application of flow correction factor
Min working pressure	4 barg (58 psig)
Max working pressure	16 barg (232 psig)
Electric controls	12VDC to 24VDC, 100VAC to 240VAC
Min inlet temperature	1.5°C (35°F)
Max inlet temperature	50°C (122°F)
Min ambient temperature	5°C (41°F)

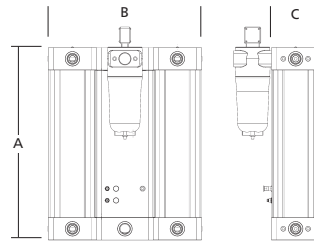

Operating pressure barg (psig)	4 (58)	5 (72)	6 (87)	7 (100)	8 (116)	9 (130)	10 (145)	11 (160)	12 (174)	13 (189)	14 (203)	15 (218)	16 (232)
Pressure correction factor (PCF)*	0.62	0.75	0.87	1	1.12	1.25	1.37	1.5	1.62	1.75	1.87	2.0	2.12

*Always use the pressure correction factor (PCF) closest to the actual inlet pressure condition

Temperature °C (°F)	20 (68)	25 (77)	30 (86)	35 (95)	40 (104)	45 (113)	50 (122)	Dewpoint °C (°F)	-40 (-40)	-70 (-100)
Temperature correction factor (TCF)	1.07	1.06	1.04	1.00	0.93	0.78	0.64	Dewpoint correction factor (DCF)	1	0.7

13.3 Purge plug identification

The table below shows the purge plug fitted to all models across the range of operating pressures.

Dryer Model	Operating pressure (barg)												
	4	5	6	7	8	9	10	11	12	13	14	15	16
PD035	2.8	2.5	2.3	2.2	2.1	2.0	1.9	1.9	1.7	1.7	1.6	1.6	1.6
PD045	2.8	2.5	2.3	2.2	2.0	1.9	1.8	1.7	1.7	1.6	1.6	1.5	1.5
PD055	3.1	2.8	2.6	2.4	2.3	2.1	2.0	1.9	1.9	1.8	1.7	1.7	1.6
PD065	3.3	3.0	2.8	2.6	2.5	2.3	2.2	2.1	2.0	2.0	1.9	1.8	1.8
PD085	3.8	3.5	3.2	3.0	2.8	2.7	2.6	2.4	2.3	2.3	2.2	2.1	2.0
PD105	4.3	3.9	3.6	3.4	3.2	3.0	2.9	2.7	2.6	2.5	2.4	2.3	2.3
PD135	4.9	4.4	4.1	3.8	3.6	3.4	3.2	3.1	3.0	2.9	2.8	2.7	2.6
PD175	5.5	5.1	4.7	4.4	4.1	3.9	3.7	3.6	3.4	3.3	3.2	3.1	3.0
PD215	2x4.3	2x3.9	2x3.6	2x3.4	2x3.2	2x3.0	2x2.9	2x2.7	2x2.6	2x2.5	2x2.4	2x2.3	2x2.3
PD275	2x4.9	2x4.4	2x4.1	2x3.8	2x3.6	2x3.4	2x3.2	2x3.1	2x3.0	2x2.9	2x2.8	2x2.7	2x2.6
PD365	2x5.5	5x5.1	2x4.7	2x4.4	2x4.1	2x3.9	2x3.7	2x3.6	2x3.4	2x3.3	2x3.2	2x3.1	2x3.0

14. Environmental conditions

All dryers are designed to be safe under the following conditions:

- Indoor use
- Altitude up to 2000m
- Ambient temperature 5°C to 40°C
- Maximum RH 80% for temperatures up to 31°C, decreasing linearly to 50% RH at 40°C
- Mains supply voltage fluctuations not to exceed +/- 10% of nominal
- Transient over voltage IEC664 Class II
- Pollution degree 2, IEC 664

For operation extended from the above conditions, please contact Walker Filtration.

15. Warranties and liabilities

Claims for warranty and liability concerning personal injury or material damage are excluded if they resulted due to one or more of the following factors:

- Inappropriate use or application of the dryer.
- Technically incorrect installation, startup operation or maintenance of the dryer.
- Operation of a known damaged dryer.
- Failure to observe the information given in this manual concerning all life phases of the dryer.
- Undertaking constructional or operational modifications to the dryer without prior agreement with Walker Filtration.
- Inadequate monitoring and replacement of components of the dryer that are subject to wear or consumable.
- Improper completion of repairs.
- Use of non-original or non-approved parts for service or maintenance.

16. EC Declaration of Conformity

EC DECLARATION OF CONFORMITY

98/37/EC, 2006/95/EC, 2004/108/EC, 97/23/EC

Name of Manufacturer

Walker Filtration Ltd

Address of Manufacturer

Spire Road, Glover East, Washington, Tyne & Wear, NE37 3ES. England

Description of Product:

Compressed Air Dryer

Designation of Product

PD035, PD045, PD055, PD065, PD085, PD105, PD135, PD175,
PD215, PD275 and PD365

Standards Used:

ISO 12100-2:2003, BS EN 60204-1:2006, BS EN 61000-6-1:2007
BS EN 61000-6-2:2005, BS EN 61000-6-3:2007, BS EN 61000-6-4:2007,
ASME VIII Div. I.:1998

Notified Body (97/23/EC only):

Lloyd's Register EMEA - Notified Body No 0038
71 Fenchurch Street, London EC3M 4BS. England

Notified Body (Quality Systems): ISO9001:2000-LRQ0930553

Lloyd's Register EMEA - Notified Body No 0038
Hiramford, Middlemarch Office Village, Siskin Drive, Coventry, CV3 4FJ. England

Conformity Assessment Module (97/23/EC only):

Module B - COV0712098/1
Module C1 - COV0712137/2

Name of Authorized Representative

Alan Hodgson

Position of Authorized Representative

Technical Manager

Declaration

I declare, on behalf of Walker Filtration Ltd and as the authorised representative, that the above stated product conforms to the requirements of the applicable New Approach Directives.



08/06/2007

WALKER FILTRATION

www.walkerfiltration.com

telephone: +44 (0)191 417 7816

fax: +44 (0)191 415 3748



Walker Filtration Ltd
Spire Road, Glover East,
Washington, Tyne & Wear,
NE37 3ES, UK
Tel: +44 (0) 191 417 7816
Fax: +44 (0) 191 415 3748
email: sales@walkerfiltration.co.uk
www.walkerfiltration.com



Walker Filtration PTY Ltd
3A Kia Court, Preston,
Victoria 3072,
Australia
Tel: +61 (0) 3 9480 0750
Fax: +61 (0) 3 9495 1044
email: sales@walkerfiltration.com.au
www.walkerfiltration.com.au

Walker Filtration Inc
2220 West 50th Street,
Erie, PA 16506,
USA
Tel: +1 814 836 2900
Fax: +1 814 836 7921
email: info@walkerfiltration.com
www.walkerfiltration.com

Walker Filtration SA
Unit 5, New Era Etx. 1.
Springs ZA-1559,
South Africa
t +27 (0) 11 813 1351
f +27 (0) 11 813 1356
www.walkerfiltration.com

42 209 001 01

Walker Filtration Ltd. reserves the right to make changes and improvements to the product and / or this manual without prior notice.