

**HEATLESS DESICCANT AIR DRYER**

***HDT 170 to 850 U***

Ⓞ

***USER'S MAINTENANCE  
AND SPARE PARTS MANUAL***

Ⓞ

***ISSUE 2006***

Dear Customer,

thank you for choosing our product. In order to get the best performances in the use of this product, please read carefully this manual. To avoid incorrect operation of the equipment and possible physical risk to the operator, please read and strictly follow the instructions contained in this manual. Note, these instructions are in addition to the safety rules that apply in the country where the dryer is installed.

Before packing for shipment each **HDT** series heatless adsorption air dryer is subjected to a rigorous test to ensure the absence of any manufacturing faults and to demonstrate that the device can perform all the functions for which it has been designed.

Once the dryer has been properly installed according to the instructions in this manual, it will be ready for use without any further adjustment. The operation is fully automatic, and the maintenance must be performed regularly, as detailed in the following chapters.

**This manual must be maintained available in any moment for future references and it has to be intended as inherent part of the relevant dryer.**

Due to the continuous technical evolution, we reserve the right to introduce any necessary change without giving previous notice.



Should you experience any trouble, or for further information, please do not hesitate to contact us.

### IDENTIFICATION PLATE

The product identification plate shows all the primary data of the machine. Upon installation, fill in the table shown on the side copying the data shown on the identification plate. These data must always be referred to the manufacturer or to the dealer when information or spare parts are needed, even during the warranty period.

The removal or the alteration of the identification plate will void the warranty rights.

- Model ⇨
- Serial No. ⇨
- Code ⇨
- Nominal Flow Rate ⇨
- Max Air Pressure ⇨
- Max Inlet Air Temperature ⇨
- Ambient Temperature ⇨
- Desiccant (type and Q.ty) ⇨
- Electric Supply ⇨
- Electric Nominal Power ⇨
- Fuse Max. ⇨
- Manufactured ⇨

Model	<input type="text"/>
Serial No.	<input type="text"/>
Code	<input type="text"/>
Nominal Flow Rate	<input type="text"/> scfm
Max Air Pressure	<input type="text"/> psig
Max Inlet Air Temp.	<input type="text"/> °F
Ambient Temp.	<input type="text"/> °F
Desiccant	<input type="text"/> Molecular Sieve/ type/lbs
Electric Supply	<input type="text"/> V/Hz
Electric Nominal Power	<input type="text"/> W
Fuse Max	<input type="text"/> A
Manufactured	<input type="text"/> 
	
<input type="text"/>	

TAD0001

### WARRANTY CONDITIONS

For 12 months from the installation date, but no longer than 14 months from the delivery date, the warranty covers eventual faulty parts, which will be repaired or replaced free of charge, except the travel, hotel and restaurant expenses of our engineer.

The warranty doesn't cover any responsibility for direct or indirect damages to persons, animals or equipment caused by improper usage or maintenance, and it's limited to manufacturing faults only.

The right to warranty repairs is subordinated to the strict compliance with the installation, use and maintenance instructions contained in this manual.

The warranty will be immediately voided in case of even small changes or alterations to the dryer.

To request repairs during the warranty period, the data reported on the identification plate must be notified.

## **1. SAFETY RULES**

- 1.1 Definition of the safety symbols used
- 1.2 Warnings
- 1.3 Proper Use of the Dryer

## **2. INSTALLATION**

- 2.1 Transport
- 2.2 Installation site
- 2.3 Installation layout
- 2.4 Correction factors
- 2.5 Connection to the Compressed Air System
- 2.6 Connection to the Mains
- 2.7 Inlet filter condensate drain

## **3. START UP**

- 3.1 Preliminary Operations
- 3.2 First Start-Up
- 3.3 Operation and Switching-Off

## **4. TECHNICAL SPECIFICATIONS**

- 4.1 Technical specifications

## **5. TECHNICAL DESCRIPTION**

- 5.1 Control panel
- 5.2 Description of operation
- 5.3 Flow Diagram
- 5.4 Operation
- 5.5 Electronic Controller DDC15
- 5.6 DewPoint meter (Optional)
- 5.7 Pressure switches of "Fail to switch alarm" (Optional)

## **6. MAINTENANCE, TROUBLESHOOTING, SPARES AND DISMANTLING**

- 6.1 Controls and Maintenance
- 6.2 Troubleshooting
- 6.3 Suggested Spare Parts
- 6.4 Dismantling of the Dryer

## **7. ATTACHMENTS**

- 7.1 Dryer dimensions
- 7.2 Exploded view
- 7.3 Electric Diagram

## 1.1 DEFINITION OF THE SAFETY SYMBOLS USED



Before attempting any intervention on the dryer, read carefully the instructions reported in this use and maintenance manual.



General warning sign. Risk of danger or possibility of damage to the machine. Read carefully the text related to this sign.



Electrical hazard. The relevant text outlines conditions which could result fatal. The related instructions must be strictly respected.



Danger hazard. Part or system under pressure.



Danger hazard. Component or system which during the operation can reach high temperature.



Danger hazard. It's absolutely forbidden to breath the air treated with this apparatus.



Danger hazard: It's absolutely forbidden to use water to extinguish fire on the dryer or in the surrounding area.



Danger hazard; It's absolutely forbidden to operate the machine when the parts (under pressure or electric panels) are not in place or have been tampered with and changed.



Danger hazard: machine level noise could be higher than 85 dBA. It is mandatory to install the machine in dedicated area where people are not normally present. The installator and/or the user is responsible for correct installation of the dryer, in order to prevent noise propagation to the near work environment. The installator and/or the user is also responsible for the safety signs affixing into installation site.



Attention: the user that intervenes to the machine must wear hearing protection before to operate into the dryer. Each employee must select proper PPD (Personal Protection Device) hearing protector ( earmuffs, ear canal caps and earplugs) in order to prevent any uneasiness that could cause dangerous situation for him.



Maintenance and/or control operation to be very carefully performed by qualified personnel <sup>1</sup>.



Compressed air inlet connection point.



Compressed air outlet connection point.



Condensate drain connection point.



Operations which can be worked out by the operator of the machine, if qualified <sup>1</sup>.

**NOTE :** Text to be taken into account, but not involving safety precautions.



In designing this unit a lot of care has been devoted to the protection of the environment:

- Dryer and relevant packaging composed of recyclable materials.
- Energy saving design.

Not to spoil our commitment, the user should follow the few ecological suggestions marked with this sign.

<sup>1</sup> Experienced and trained personnel acquainted with the relevant rules and laws, capable to perform the needed activities and to identify and avoid possible dangerous situations while handling, installing, using and servicing the machine.

## 1.2 WARNINGS



Compressed air is a highly hazardous energy source. Never work on the dryer with parts under pressure. Never point the compressed air or the condensate drain jet towards anybody.

The user is responsible for the installation of the dryer, which has to be executed on the basis of the instructions given in the "Installation" chapter. Otherwise, the warranty will be voided and dangerous situations for the personnel and/or damages to the machine could occur.



Only qualified personnel can use and service electrically powered devices. Before attempting any maintenance action, the following conditions must be satisfied :

- Ensure that any part of the machine is under voltage and that it cannot be connected to the mains.
- Ensure that any part of the dryer is under pressure and that it cannot be connected to the compressed air system.



Any change to the machine or to the relevant operating parameters, if not previously verified and authorised by the Manufacturer, in addition to create the possibility of dangerous conditions it will void the warranty.



Don't use water to extinguish fire on the dryer or in the surrounding area.

## 1.3 PROPER USE OF THE DRYER

This dryer has been designed, manufactured and tested only to be used to separate the humidity normally contained in compressed air. Any other use has to be considered improper. The Manufacturer will not be responsible for any problem arising from improper use; the user will be in any case responsible for any resulting damage.

Moreover, the correct use requires the compliance with the installation conditions, in particular:

- Voltage and frequency of the mains.
- Pressure, temperature and flow-rate of the incoming air.
- Ambient temperature.

This dryer is supplied tested and fully assembled. The only operation left to the user is the connection to the plant in compliance with the instructions given in the following chapters.



The purpose of the machine is the separation of water and eventual oil particles present in compressed air. The dried air cannot be used for respiration purposes or for operations leading to direct contact with foodstuff, unless subject to further treatments.

## 2.1 TRANSPORT

Once verified the integrity of the packaging, place the unit near to the installation point and unpack the contents.

- To move the packaged unit we suggest to use a suitable crane or forklift. We do not recommend using hands.
- Handle with care. Heavy blows could cause irreparable damage.
- Even when packaged, keep the machine protected from severity of the weather.



The packaging materials are recyclable. Each single material must be properly disposed in a manner complying with the rules in force in the destination country.

## 2.2 INSTALLATION SITE



Particular care is required in selecting the installation site, as an improper location could jeopardise the proper operation of the dryer.

This unit is not suitable to be used in explosive atmosphere, where risk of fire could exist, or in presence of gaseous or solid polluting material.



Don't use water to extinguish fire on the dryer or in the surrounding area.



Machine level noise could be higher than 85 dBA. It is mandatory to install the machine in dedicated area where people are not normally present. The installer and/or the user is responsible for correct installation of the dryer, in order to prevent noise propagation to the near work environment. The installer and/or the user is also responsible for the safety signs affixing into installation site.



The user that intervenes to the machine must wear hearing protection before to operate into the dryer. Each employee must select proper PPD (Personal Protection Device) hearing protector (earmuffs, ear canal caps and earplugs) in order to prevent any uneasiness that could cause dangerous situation for him.

Minimal installation requirements:

- Select a clean room dry, free from dust, and protected from atmospheric disturbances.
- The supporting area must be smooth, horizontal and able to hold the weight of the dryer.
- Minimum ambient temperature 34 °F (1 °C)
- Maximum ambient temperature 120 °F (50 °C).
- Allow at least a clearance of 1 m on each side of the dryer to facilitate possible maintenance operations.
- The dryer doesn't require to be fixed to the supporting surface.

## 2.3 INSTALLATION LAYOUT

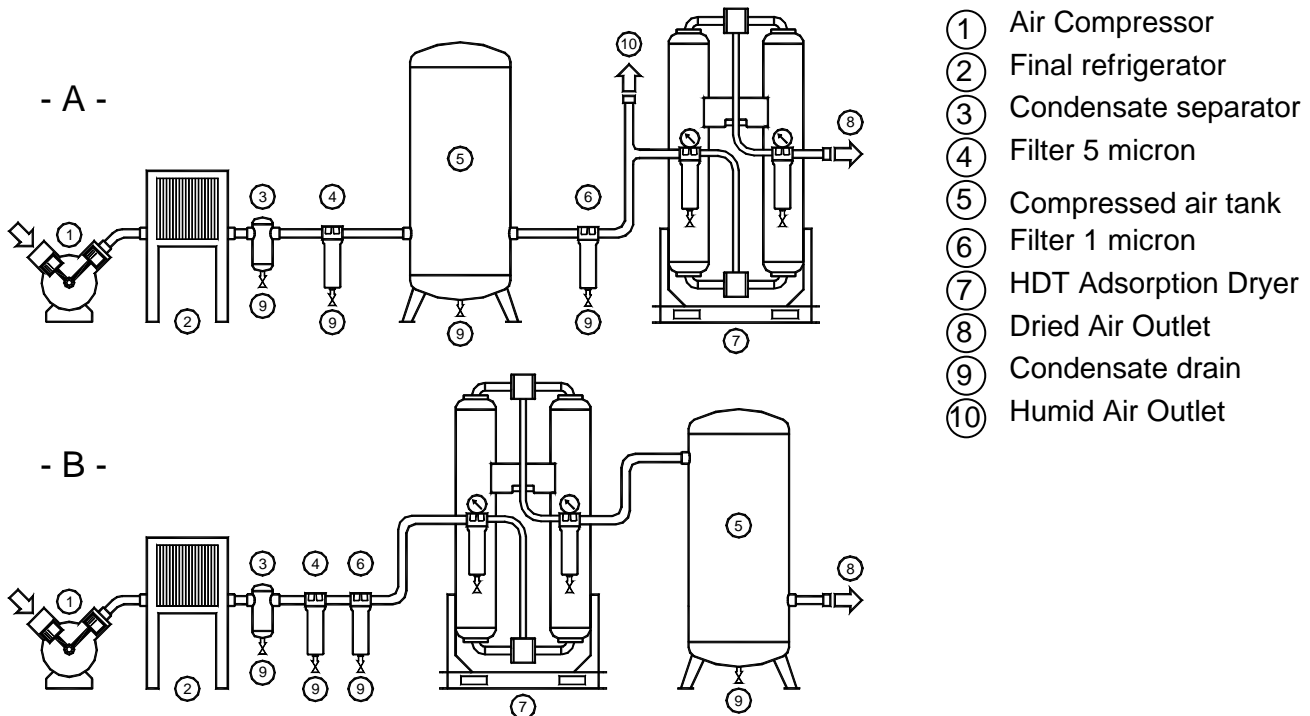

- ① Air Compressor
- ② Final refrigerator
- ③ Condensate separator
- ④ Filter 5 micron
- ⑤ Compressed air tank
- ⑥ Filter 1 micron
- ⑦ HDT Adsorption Dryer
- ⑧ Dried Air Outlet
- ⑨ Condensate drain
- ⑩ Humid Air Outlet



**Dryer is supplied with 0.01 micron filter on the inlet and a 1 micron filter on the outlet. It is recommended to install both 5 micron and 1 micron filter before the dryer, in order to protract the life of the inlet filter.**

**Type A** installation is suggested when the compressed air treated from the dryer is only a part of the total flow rate of the compressor; or when the compressor operates at reduced intermittence and the total consumption equals the compressor flow rate.

**Type B** installation is suggested when the compressed air treated from the dryer is the total flow rate of the compressor; or when the air consumption can consistently change with peak values highly exceeding the flow rate of the compressors. In this case the capacity of the tank must be sized to face with the stored air the short term and high value requests (impulsive).

## 2.4 CORRECTION FACTORS

Correction factor for operating pressure changes:												
Inlet air pressure	psig	60	70	80	90	100	110	120	125	130	140	150
Inlet air pressure	barg	4,1	4,8	5,5	6,2	6,9	7,6	8,3	8,6	9	9,7	10
Factor	F <sub>1</sub>	0,65	0,76	0,85	0,93	1,00	1,05	1,11	1,13	1,15	1,20	1,24

Correction factor for inlet air temperature changes:								
Air temperature	°F	≤ 80	90	100	105	110	115	120
Air temperature	°C	≤ 27	32	38	41	43	46	49
Factor	F <sub>2</sub>	1,13	1,08	1,00	0,96	0,90	0,85	0,79

### How to find the air flow capacity:

$$\boxed{\text{Air flow capacity}} = \boxed{\text{Nominal duty}} \times \boxed{\text{Factor (F1)}} \times \boxed{\text{Factor (F2)}}$$

#### Example:

A **HDT 250U** has a nominal duty of **250 scfm**. What is the maximum allowable flow through the dryer under the following operating conditions:

- Minimum inlet air pressure = 90 psig
- Maximum inlet air temperature = 115 °F

Each item of data has a corresponding numerical factor which multiplied by the nominal duty determines the following :

$$\boxed{\text{Air flow capacity}} = \boxed{250} \times \boxed{0.93} \times \boxed{0.85}$$

= **198 scfm** → This is the maximum air flow rate that the dryer can accept under these operating conditions.



**CHECK IF THE REGENERATION NOZZLE IS SUITABLE FOR THE REAL WORKING PRESSURE OF THE DRYER. IF YOU HAVE DOUBTS OR PROBLEMS, PLEASE CONTACT YOUR DISTRIBUTOR.**

## 2.5 CONNECTION TO THE COMPRESSED AIR SYSTEM



Operations to be performed by qualified personnel. Never operate with plants under pressure. The user is responsible to ensure that the dryer will never be operated with pressure exceeding the nominal values. Eventual over-pressure could be dangerous both for the operator and the machine.

The temperature and the amount of air entering the dryer must comply with the limits reported on the data plate. In case of treatment of air at particularly high temperature, the installation of a final refrigerator could result necessary. The cross section of the connecting piping, which must be free from dust, rust, chips and other impurities, and must be consistent with the flow-rate of the dryer.

In realising the dryer, particular measures have been taken in order to limit the vibration which could occur during the operation. Therefore we recommend to use connecting pipes able to insulate the dryer from possible vibrations originating from the line (flexible hoses, vibration damping fittings, etc.).

### How to select a suitable dryer for a given duty:

$$\boxed{\text{Minimum Std. air flow rate}} = \boxed{\text{Design air flow}} \div \boxed{\text{Factor (F1)}} \div \boxed{\text{Factor (F2)}}$$

#### Example:

Given the operating parameters below:

- Design (inlet) air flow = 300 scfm
- Minimum inlet air pressure = 90 psig
- Maximum inlet air temperature = 115°F

In order to select the correct dryer model, the required flow rate is to be divided by the correction factors relating to above mentioned parameters:

$$\boxed{\text{Minimum Std. air flow rate}} = \boxed{300} \div \boxed{0.93} \div \boxed{0.85}$$

= **380 scfm** → Therefore the model suitable for the conditions above is **HDT 420U (420 scfm - nominal duty)**.

## 2.6 CONNECTION TO THE MAINS



The connection to the mains, to be carried out by qualified personnel, and the safety systems must comply with local rules and laws.

Before connecting the unit to the electric power, verify that the voltage and the frequency available on the mains correspond to the data reported on the data plate of the dryer. In terms of voltage, a  $\pm 5\%$  tolerance is allowed. The dryer comes with a mains connecting cable already installed (3m long).

The mains socket must be provided with a **mains magneto-thermal differential breaker** ( $I_{\Delta n}=0.3A$ ).

The cross section of the power supply cables must comply with the consumption of the dryer, while keeping into account also the ambient temperature, the conditions of the mains installation, the length of the cables, and the requirements enforced by the local Power Provider.



It is mandatory to ensure the connection to the ground terminal.

## 2.7 INLET FILTER CONDENSATE DRAIN



The condensate is discharged at the same pressure of the air entering the dryer. Never point the condensate drain jet towards anybody.

The dryer is already designed to be connected to the condensate collecting plant through a flexible plastic pipe, 6mm in diameter and 1500mm long.

Connect and properly fasten the condensate drain to a collecting plant or container.

The drain cannot be connected to pressurised systems.



Don't dispose the condensate in the environment.

The condensate collected in the dryer contains oil particles released in the air by the compressor. Dispose the condensate in compliance with the local rules.

We suggest to install a water-oil separator where to convey all the condensate drain coming from compressors, dryers, tanks, filters, etc.

## 3.1 PRELIMINARY OPERATION



Verify that the operating parameters match with the nominal values reported on the data plate of the dryer (voltage, frequency, air pressure, air temperature, ambient temperature, etc.).

Before delivery, each dryer is submitted to accurate tests simulating real operating conditions. Nevertheless, the unit could be damaged during transportation. We therefore suggest to check the integrity of the dryer upon arrival and to keep it under control during the first hours of operation.



The start-up must be performed by qualified personnel.

It's mandatory that the engineer in charge will adopt safe operational conditions complying with the local safety and accident prevention requirements.



The same engineer will be responsible for the proper and safe operation of the dryer.

Never operate the dryer if their panels are not in place.

### 3.2 FIRST START-UP



At the first start-up, or in case of start-up after a long inactivity period or following to maintenance operations, comply with the instructions given below. The start-up must be performed by qualified personnel.



The user that intervenes to the machine must wear hearing protection before to operate into the dryer. Each employee must select proper PPD (Personal Protection Device) hearing protector (earmuffs, ear canal caps and earplugs) in order to prevent any uneasiness that could cause dangerous situation for him.

#### Sequence of operations:

- Verify that the factory settings, indicated in the plate “REMOVE BEFORE THE 1<sup>ST</sup> START UP” (on the DDC15 instrument), match the real operating conditions requested.
- Verify that all the steps of the “Installation” chapter have been observed.
- Verify that the connection to the compressed air system is correct and that the piping is suitably fixed.
- Verify that the condensate drain pipe is properly fastened and connected to a collection system or container.
- Remove any packaging and other material which could obstruct the area around the dryer.
- Pressurize the dryer slowly.
- Activate the mains switch.
- Verify that the DDC15 instrument is on.
- Check the piping for air leakage.
- Test the drain of the inlet filter.
- After 2 minutes from the start-up the adsorption tower B is depressurized.
- Wait for the dryer to make some cycles (there is an alternation of depressurization from tower A to tower B)
- The cycle is inverted every 2 minutes (DewPoint of -100°F / -70°C) or every 5 minutes (DewPoint of -4 °F / -40°C) or every 7.5 minutes (DewPoint of -4°F / - 20°C); it depends on the dryer set-up.

**NOTE :** During the first days of working, the DewPoint is not ensured because the adsorption material can contain humidity.

At the first start-up, or in case of start-up after a long inactivity period or following to maintenance operations, we recommend using the dryer at a reduced nominal flow of 50% during the first two days.

### 3.3 OPERATION AND SWITCHING OFF



The user that intervenes to the machine must wear hearing protection before to operate into the dryer. Each employee must select proper PPD (Personal Protection Device) hearing protector (earmuffs, ear canal caps and earplugs) in order to prevent any uneasiness that could cause dangerous situation for him.



#### Operation :

- Pressurize the dryer slowly.
- Activate the mains switch.
- Verify that the DDC15 instrument is on.
- Wait for the first interventions of the inlet filter drain or make the drain test manually.
- During the first two minutes both the towers are pressurized
- Wait for the dryer to make some cycles (there is an alternation of depressurization from tower A to tower B).



#### Switching off:

- Check if the inlet filter condensate drain works regularly.
- Stop the air flow.
- Depressurize the dryer.
- Deactivate the mains switch.

**NOTE :** During the working of the dryer, both the towers are cyclic depressurized in order to be regenerated. The depressurized tower is crossed from part of the compressed air already dried, which will be expelled outside. The noise of the compressed air during the draining is muffled by silencers.

## 4.1 TECHNICAL SPECIFICATIONS

MODEL	HDT							
	170 U	210 U	250 U	300 U	420 U	540 U	680 U	850 U
Nominal inlet air flow <sup>1</sup>	170	210	250	300	420	540	680	850
Pressure DewPoint <sup>2</sup>	-4, -40, -100 F / -20, -40, -70°C							
Nominal ambient temperature	34 to 120 F / 1 to 50 °C							
Nominal Inlet Air Temperature	100 / 38							
Max Inlet Air Temperature	120 / 50							
Nominal inlet air pressure	100 / 6.9							
Max inlet Air Pressure <sup>3</sup>	150 / 10.3							
Inlet – outlet connections	1.1/4"	1.1/4"	1.1/4"	1.1/2"	2"	2"	2.1/2"	2.1/2"
Adsorbent material - Type	Molecular sieve							
Adsorbent material - Quantity	175 / 79	215 / 98	260 / 118	310 / 140	430 / 195	550 / 250	705 / 320	870 / 395
Standard Electric Supply <sup>2</sup>	1/100-120/50-60 or 1/208-240/50-60							
Electric Nominal Power	50							
Level noise at 1 m	> 85							
Weight	510 / 232	625 / 283	670 / 305	750 / 340	890 / 403	1070 / 485	1550 / 702	1790 / 813

<sup>1</sup> The nominal conditions refer to an inlet air pressure of 10psig and a temperature of 100 F.

<sup>2</sup> To be specified in the order.

<sup>3</sup> Upon request pressures up to 230 psig.

### 5.1 CONTROL PANEL

The only interface between the dryer and the operator is the control panel shown below.

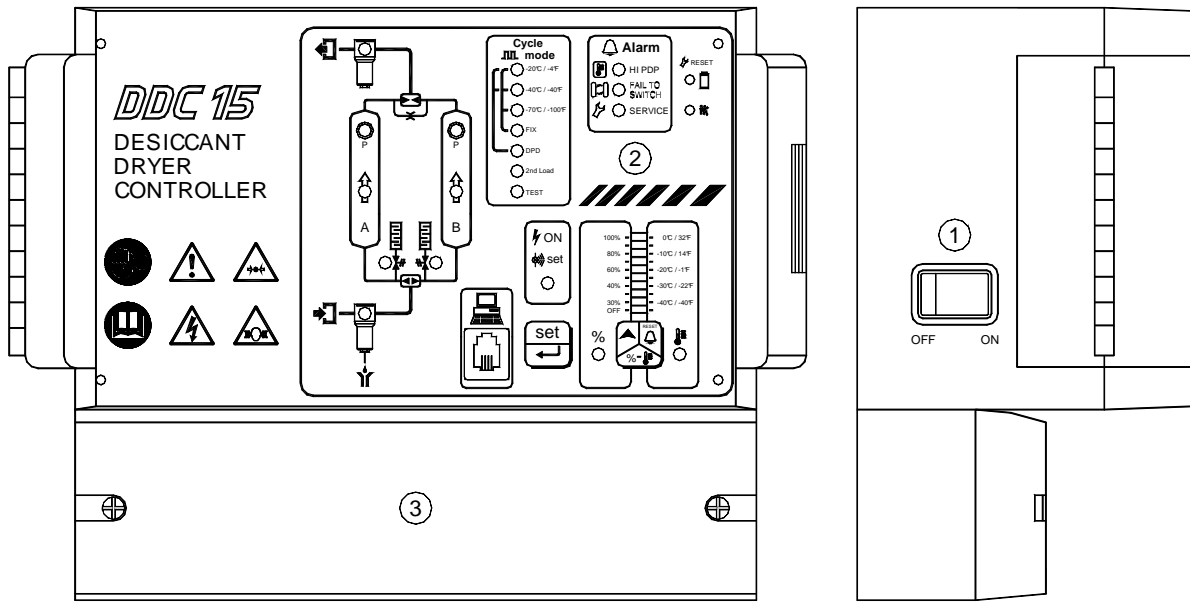

- ① Main switch
- ② DDC15 electronic device
- ③ Terminal board

### 5.2 OPERATION

The cold regenerated adsorption dryers of the HDT series are fitted with two tanks, positioned parallel to one another and filled with adsorption material (molecular sieve). While the compressed air is dried in one tower, the saturated desiccant is regenerated in the second. A minimum part of the already treated air is used for the regeneration process and eliminated along with the condensate, through the silencers.

### 5.3 FLOW DIAGRAM

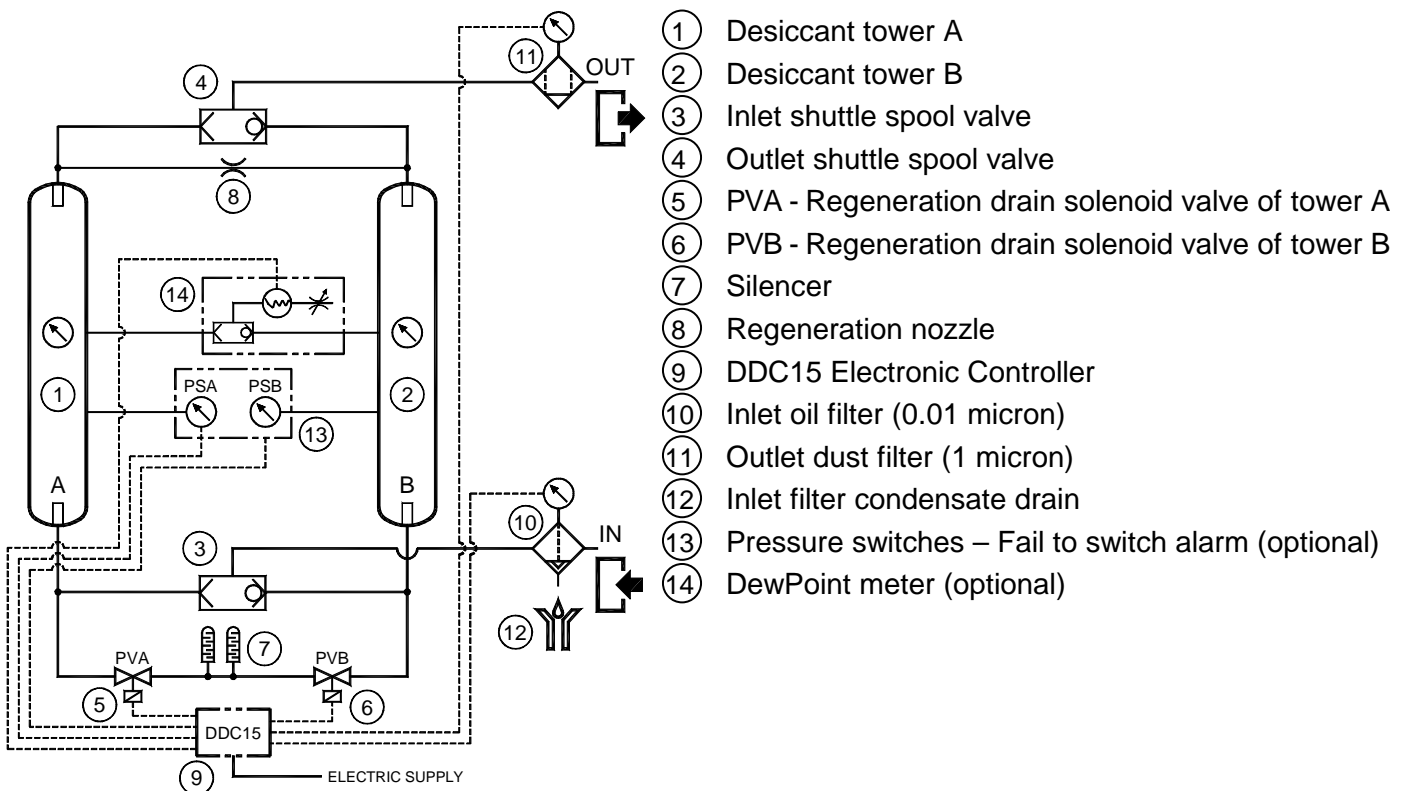

## 5.4 OPERATION

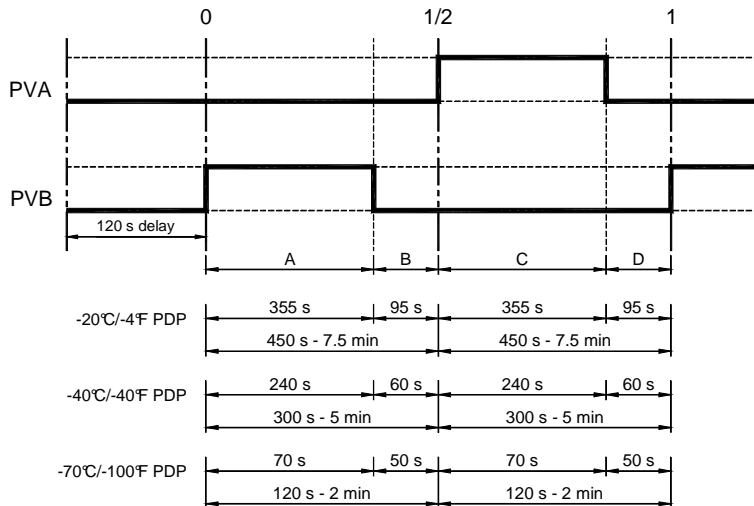

The dryer described in this manual basically takes advantage of the adsorption properties of the desiccant material which the two towers (tanks) are filled with.

These towers, with the same dimensions, are alternately crossed from the compressed air. The cycle time is set during the manufacturing phase (as well as the regeneration nozzle) according to the requested DewPoint PDP (reference model max. 10 barg) :

- 15 minutes for -4°F (-20°C)
- 10 minutes for -40°F (-40°C)
- 4 minutes for -100°F (-70°C)

### Pressurization

During the start-up both regeneration drain solenoid valves PVA and PVB (5 and 6) are closed (for about 120 seconds) to guarantee the complete pressurization of the dryer..

**Stage A** The solenoid valve PVB (6) is supplied so the tower B (2) is depressurized. Both inlet and outlet spools of shuttle valves (3 and 4) move towards tower B (side without pressure). The compressed air flow is directed to tower A (1), where the desiccant material adsorbs the humidity up to the target Dew Point.

Trough the regeneration nozzle (8) a calibrated part of dry air coming out from tower A is expanded towards tower B. This air (particularly dry for this expansion operation) while crossing tower B, dries the adsorbent material dragging away the humidity through the PVB solenoid valve (6) and the silencers (7). At the end of this stage the adsorption material of tower B is completely regenerated.

**Stage B** The solenoid valve PVB (6) is closed and then through the regeneration nozzle (8) tower B (2) is pressurized again up to the working pressure. The sum of stages A + B equals a half cycle time.

**Stage C** The solenoid valve PVA (5) is supplied so tower A (1) is depressurized. Both inlet and outlet spools of shuttle valves (3 and 4) move towards tower A (side without pressure). The compressed air flow is directed to tower B (2), where the desiccant material adsorbs the humidity up to the target DewPoint.

Trough the regeneration nozzle (8) a calibrated part of dry air coming out from tower B is expanded towards tower A. This air (particularly dry for this expansion operation) while crossing tower A, dries the adsorbent material dragging away the humidity through the PVB solenoid valve (5) and the silencers (7). At the end of this stage the adsorption material of tower A is completely regenerated.

**Stage D** The solenoid valve a PVA (5) is closed and then through the regeneration nozzle (8) tower A (1) is pressurized again up to the working pressure. The sum of stages C + D equals a half cycle time. At the end the cycle starts up' again from phase A.

Note: The cycles are symmetrical therefore A=C and B=D

The desiccant material, if contaminated from lubricant oil, loses its adsorption propriety. Moreover during operation, the desiccant can release solid particles (powders) particularly abrasive and extremely damaging for the final users.

For this reason the dryer is equipped with two high-efficiency filters:

- Inlet filter, 0.01 micron filtration grade, with differential gauge and electronic timed drain or electronic level drain.
- Outlet filter, 1 micron filtration grade, with differential gauge and manual drain.

### 5.5 ELECTRONIC INSTRUMENT DDC 15

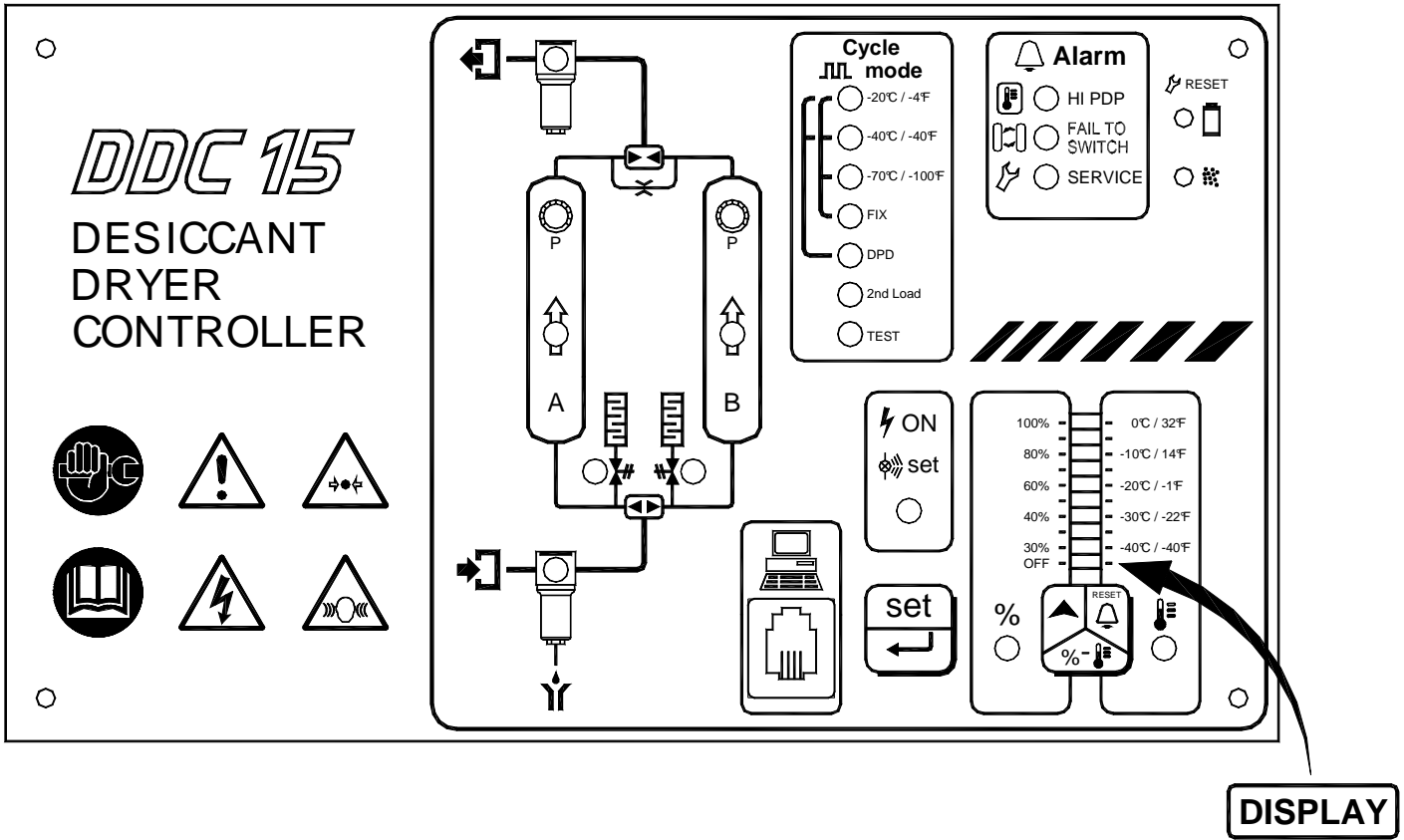

	Key - On during programming		LED - On = tower under pressure
	Key - Test condensate drain / increase value / reset alarm		LED - on = inlet filter clogged
	LED - on = device powered		LED - on = outlet filter clogged
	- flashing = under programming		LED - Alarm: DewPoint too high
	LED - on = display shows % of set load		LED - Alarm: operating cycle did not switch
	LED - on = display shows DewPoint temperature		LED - Alarm: maintenance intervention
	LED - on = tower under adsorption		Key - reset cartridge replacement
	LED - on = air breathing solenoid valve regeneration open		Key - reset desiccant replacement

The correct operation of the dryer is controlled and monitored constantly by the DDC15 device. The device carries out many functions:

- It displays the operating status through the synoptic LED panel;
- It can be used to select the operating DewPoint;
- It can be used to select the operating mode (FIX, DPD and TEST);
- It can be used to enable the “Energy Save” function.

**5.5.1 SYNOPTIC PANEL** – The synoptic LED panel is divided into four different display area. Each one represents the specific functions of the dryer, more precisely:

1. the LEDs on the left, positioned on the **flow diagram**, represent the various operating phases of the dryer.
2. the LEDs of the “**Cycle mode**” menu display the operating mode of the dryer, selected by the operator during the programming phase (see specific paragraph).
3. the LEDs of the “**Alarm**” menu represent any anomaly and/or malfunctioning of the machine.
4. the LEDs and the **DISPLAY** on the right display the various load percentages the dryer operates with.



Press the mains switch of the device to switch on the LED

The LEDs on the flow diagram of the synoptic panel show the operating status of the dryer, precisely:

- At **start up** both the breathing solenoid valves are closed (for about 120 seconds) therefore the relevant LEDs are off. The compressed air passes through both drying towers, to pressurize the dryer and therefore the LEDs are on.
- After 120 sec. The dryer starts the first operating cycle: "**Phase A**", tower B is de-pressurized, LED B switches off and the PVB solenoid valve is opened (LED B on) to vent the air used for the regeneration.
- Afterwards, the dryer starts the "**Phase B**" re-pressurization of tower B, therefore solenoid valve PVB shuts down (LED B off). LED B switches on when the pressure switch reaches the calibration value (if the pressure-switch Kit is installed– optional).
- When the towers are once again pressure balanced the second part of the cycle time starts with "**Phase C**", where tower A is de-pressurized, LED A switches off and the solenoid valve PVA is opened (LED A on) to vent the air used for regeneration.
- The machine cycle ends with the re-pressurization "**Phase D**" of tower A, the solenoid valve PVA closes (LED A off). LED A switches on when the pressure switch reaches the calibration value (if the pressure-switch Kit is installed– optional).

According to the selected operating mode (see paragraph DIP-SWITCHES) the following LEDs of the "**Cycle mode**" menu can be on:

**Mode : FIX**

The dryer runs with fixed cycle times.

	<p>Pressure DewPoint PDP : <b>-4°F (-20°C)</b></p>		<p>Pressure DewPoint PDP : <b>-40°F (-40°C)</b></p>		<p>Pressure DewPoint PDP : <b>-100°F (-70°C)</b></p>
--	--	--	---	--	--

**Mode: DPD**

The dryer operates with cycle times proportional to the applied load (if the DewPoint probe is installed – optional).

	<p>Pressure DewPoint PDP : <b>-4°F (-20°C)</b></p>		<p>Pressure DewPoint PDP : <b>-40°F (-40°C)</b></p>
--	--	--	---

**Mode: TEST**

Diagnostic cycle, with step-by-step operation to make troubleshooting operations easier.

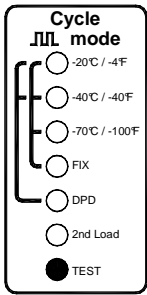

**Mode :**

**FIX**

**Function :**

**2nd Load**

The dryer operates with fixed cycle times and allows the operator to choose, only in FIX modality through an external contact, a second setting for the foreseen applied load (installation directly downstream of one or more than one compressor).

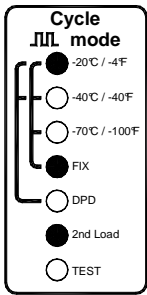

Pressure DewPoint PDP :  
**-4°F (-20°C)**

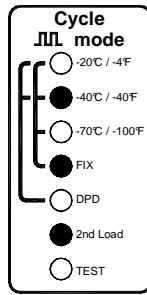

Pressure DewPoint PDP :  
**-40°F (-40°C)**

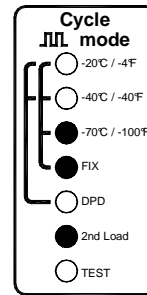

Pressure DewPoint PDP :  
**-100°F (-70°C)**

The synoptic panel shows any anomaly and/or malfunctioning through the LEDs of the “Alarm” menu. The LEDs flash when the alarm is active and they stay on when the alarm has stopped, but has not yet been reset. More precisely:

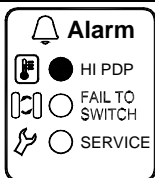

When the LED is flashing it means the alarm went off for a high DewPoint. The function can be activated only if the DewPoint probe is installed – optional – and only after having correctly set the relating DIP-SWITCH (see specific paragraph).

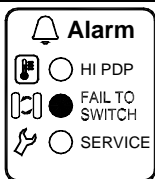







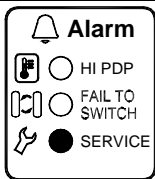







the LED flashes when the towers did not switch properly. This alarm is particularly important because it helps avoid possible de-pressurizations of the distribution circuit through the dryer. The function can be enabled only if the pressure switch kit is installed – optional – and only after having correctly set the relating DIP-SWITCH (see specific paragraph).







If the “SERVICE” LED and the  LED of the flow diagram are flashing at the same time, it means that the dryer inlet filter is clogged and therefore it must be replaced. This alarm does not affect the operation of the dryer, but maintenance interventions are needed. Please refer to the User and Maintenance manual of the filter itself.







If the “SERVICE” LED and the  LED of the flow diagram are flashing at the same time, it means that the dryer outlet filter is clogged and therefore it must be replaced. This alarm does not affect the operation of the dryer, but maintenance interventions are needed. Please refer to the User and Maintenance manual of the filter itself.









 <b>Alarm</b>  HI PDP  FAIL TO SWITCH  SERVICE	 <p>If the "SERVICE" LED and both  -  LEDs of the flow diagram are flashing at the same time, the timer for the programmed maintenance of the filters has gone off.</p>
 <b>Alarm</b>  HI PDP  FAIL TO SWITCH  SERVICE	 <p>If the "SERVICE" LED and both  -  LEDs of the flow diagram are flashing at the same time, the timer for the programmed maintenance of the desiccant material has gone off.</p>

When the  LED is on, the 10 LED DISPLAY shows the load percentage of the "1st Load", set by the operator during the programming phase. By pressing the key , the DISPLAY shows the load percentage of the "2nd Load" and the LED  of the "Cycle mode" menu lights up at the same time.

Press the  key again and the 10 LED DISPLAY shows the DewPoint temperature read by the DewPoint meter (if installed); at the same time the  LED lights up. The chart below shows the values matching each LED of the DISPLAY :

LED N.	1	2	3	4	5	6	7	8	9	10
<b>Display of load %</b>	OFF	30	-	40	50	60	70	80	90	100
<b>Display of DewPoint °F</b>	32	23	14	5	-4	-13	-22	-31	-40	-49
<b>Display of DewPoint °C</b>	0	-5	-10	-15	-20	-25	-30	-35	-40	-45
<b>Note :</b> In DewPoint display, the intermediate temperatures are indicated by the two LEDs adjacent the value (for example at 27.5°F (-2.5°C) both LEDs 1 and 2 light up, or at -8.5°F (-22.5°C) LEDs 5 and 6 light up).										
<b>Note :</b> In DewPoint display LED 1 flashes for temperatures higher than 50°F (+10°C), whereas LED 10 flashes for temperatures lower than -76°F (-60°C). In case of anomalies on the probe all the LEDs switch off.										

**5.5.2 PROGRAMMING (SET-UP) LOAD %** – Keep the key  pressed for at least 2 seconds to access the programming section, LED  flashes to confirm access into the programming mode. To increase the displayed value, press the key . Press the key  to memorize the new set value and move onto the next one (if the key  is not pressed, the new parameter is not memorized). The following parameters can be programmed:

Parameter	Display	Programmable value	Std. Value
1st Load	 ON  set Leds  and  flash	30, 40, 50, 60, 70, 80, 90, 100 %	100 %
2nd Load	 ON  set Leds  ,  and  <sup>2nd Load</sup> flash	Between OFF and 100 %	100 %

To exit the programming mode, wait 1 minute or keep the key  pressed for 2 seconds. The new parameters shall be used at the beginning of the first new operating cycle.

**5.5.2.1 CALCULATING THE LOAD %** – Calculating the load percentage to set on the DDC15 device is a very important operation, because it helps save energy. The operator must calculate the percentages very carefully, considering that the operator is perfectly aware of the max. air load, of the max. inlet air temperature, as well as the real minimum pressure during operation.



**Only qualified personnel can set the loads. If the load % is too low, the desiccant material will get deteriorated, because it is regenerated for shorter times than necessary. The manufacturer cannot be held responsible for any malfunctioning of the dryer in case of wrong operating settings.**

To determine the load percentages to set on the device, refer to the following example, if the real operating parameters are known.

**EXAMPLE:**

- Max. inlet air flow = 390 scfm
- Minimum operating pressure = 80 psig ( $\rightarrow F_1=0.85$ )
- Max. inlet air temperature = 105°F ( $\rightarrow F_2=0.96$ )
- Installed dryer = HDT 540 U

With reference to paragraph 2.4 “CORRECTION FACTORS”, the real load applied to the dryer equals:

$$\text{Real load} = 390 / F_1 / F_2 = 390 / 0.85 / 0.96 = 478 \text{ scfm}$$

$$\text{Load \% actually applied} = 478 / 540 \times 100 = 88.5 \%$$

To optimize the operation of the dryer, the operator must set a load of the 1<sup>st</sup> Load equal to 90% on the 10 LED display of the device (from LED N. 8 of bar). As indicated above, slightly round up the set percentage to ensure the correct use and preservation of the desiccant material.

The instructions indicated previously can also be applied to the 2nd Load.

**5.5.3 OPERATION CONFIGURATION** – The electronic board, indicated below and positioned inside the DDC15 device, allows for the adjustment and control of the main operating parameters.



Only qualified personnel must configure the dryer.

**Before any intervention, verify that:**

- no part of the machine is powered and that it cannot be connected to the mains supply.

Access the part by removing the terminal board cover (No. 3 of the control panel - see paragraph 5.1) and/or the synoptic panel of the DDC15 device.



Any modifications to the operating configuration not compatible with the ones recommended by the manufacturer can cause malfunctioning, possible damages to parts of the machine and a premature deterioration of the adsorbent material and of the inlet and outlet dryer filters.

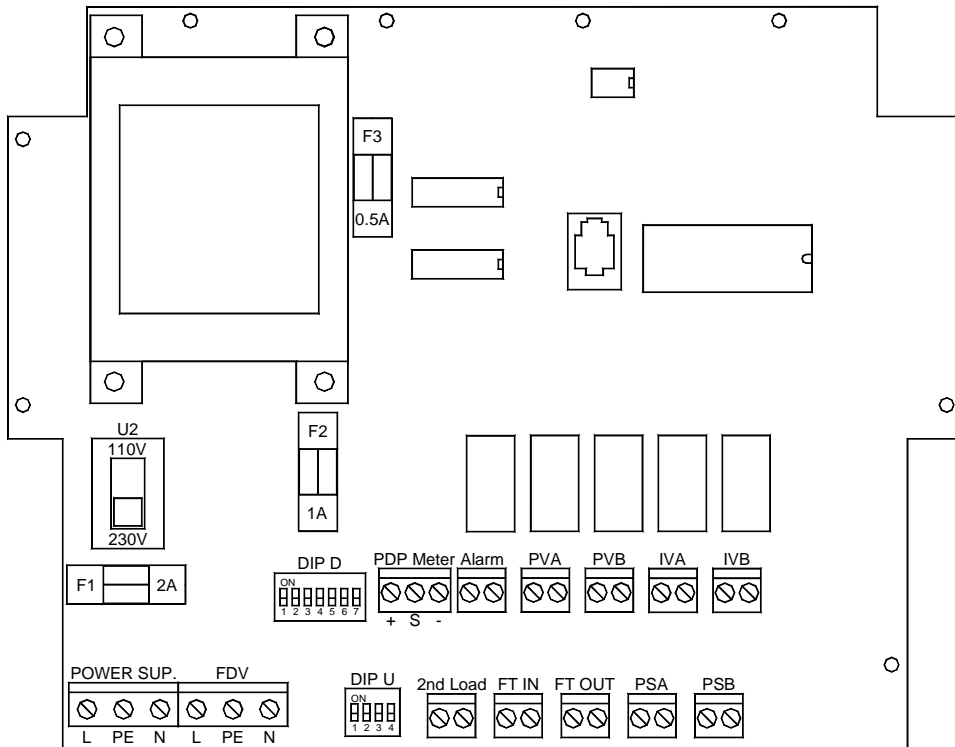

**5.5.3.1 POWER SELECTOR** – The DDC15 device is able to operate with different voltage ranges (1/100-120V/50-60Hz or 1/220-240V/50-60Hz). Before starting up the machine it is necessary to open the device and verify that the U2 switch of the electronic board is set to the correct supply voltage:

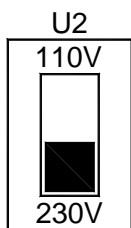

With the switch in the lower position, the DDC15 device must be powered at 220-240 V.

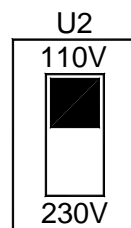

With the switch in the upper position, the DDC15 device must be powered at 110-120 V.



The automatic drain on the filter at the dryer inlet, is supplied according to the power voltage indicated in the order; verify its compatibility with the former settings and especially with the plate data.

**5.5.3.2 DIP-SWITCHES** – The DDC15 electronic board is fitted with two series of DIP-SWITCHES that are set during the dryer test phase. If there are specific functional or control requirements, the Customer has the possibility of changing the operating parameters, by simply changing the set-up of the DIP-SWITCHES.



Only qualified personnel can perform the adjustment interventions.

**Before any intervention verify that:**

- **the machine has no parts under voltage** and that it cannot be re-connected to the mains.

**The modification to the operating parameters through the variation of the position of the DIP-SWITCHES will be active only when the dryer starts up again.**

The second series of DIP-SWITCHES (DIP D) allows for the setting of the following parameters:

DIP D		
	<b>DIP D1 and DIP D2</b> : <b>Selecting the operating cycle.</b> The dryer can operate according to different operating cycles, according to the requested DewPoint or according to a diagnostic cycle (see specific paragraph).	1 OFF & 2 OFF = Cycle -40°F/-40°C 1 ON & 2 OFF = Cycle -100°F/-70°C 1 OFF & 2 ON = Cycle -4°F/-20°C 1 ON & 2 ON = Cycle Test
	<b>DIP D3</b> : <b>DPD Cycle.</b> It can be used to start the operating mode with cycle times proportional to the applied load (if the second DewPoint probe is installed- optional). Priority must be given to the selection of DIPs D1 and DIP D2.	OFF = Not enabled (standard) ON = Enabled
	<b>DIP D4</b> : <b>HI PDP alarm.</b> It can be used to set off the alarm for a very high DewPoint (if the DewPoint probe is installed- optional).	OFF = Not enabled (standard) ON = Enabled
	<b>DIP D5</b> : <b>Use.</b> It can be used to modify the internal maintenance timer, selecting a work cycle up to 3000 hours/year or higher (see specific paragraph "MAINTENANCE").	OFF = up to 3000 hours/year (standard) ON = over 3000 hours/year
	<b>DIP D6</b> : <b>Not used.</b>	-
	<b>DIP D7</b> : <b>DewPoint probe.</b>	OFF = probe disabled ON = probe enabled (standard)

The first series of (DIP U) allows for the setting of the following parameters:

DIP U		
	<b>DIP U1</b> : <b>Pressure.</b> The DDC15 device can operate with two different pressure ranges, according to the operating limits used to design the dryer (Standard Max. 10,3 barg; optional Max. 16 barg).	OFF = Low pressure - Max. 10,3 barg (standard) ON = High pressure - Max. 16 barg
	<b>DIP U2</b> : <b>Fail to switch alarm.</b> It can be used to enable the pressure switches to control the "Fail to Switch alarm" function.	OFF = Not installed (standard) ON = Installed
	<b>DIP U3</b> : <b>FT Filter Management.</b> Two differential manometers are connected to the inlet and outlet filters. They show the level of clogging of the cartridge and through an electric contact they transfer this signal to the DDC15 device. The signal can be managed like a normally closed contact (pos. OFF) or an open contact (pos. ON).	OFF = contact closed → filter OK ON = contact open → filter OK
	<b>DIP U4</b> : <b>Not used.</b>	-

**5.5.4 OPERATING CYCLES** – As described previously, the dryer can operate according to three different operating modes: FIX, DPD and TEST.

**5.5.4.1 FIX** – In FIX mode, the cycle times are managed according to the following operating parameters:

- required DewPoint (-4°F, -40°F, -100°F / -20°C, -40°C, -70°C);
- set load percentage (OFF ... 100%);
- maximum dryer pressure (Max. 150psig / 10,3 barg or Max. 230psig / 16 barg)

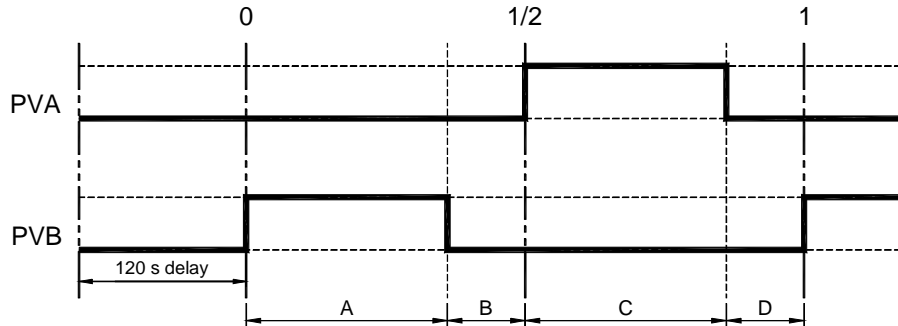

The table below shows the cycle times according to the operating configuration of the dryer:

Load	Low pressure 150 psig						High pressure 230 psig					
	-4°F / -20°C		-40°F / -40°C		-100°F / -70°C		-4°F / -20°C		-40°F / -40°C		-100°F / -70°C	
	Time A	Time B	Time A	Time B	Time A	Time B	Time A	Time B	Time A	Time B	Time A	Time B
[%]	[s]	[s]	[s]	[s]	[s]	[s]	[s]	[s]	[s]	[s]	[s]	[s]
100	355	95	240	60	70	50	270	180	180	120	46	74
90	320	130	217	83	64	56	244	206	163	137	42	78
80	285	165	193	107	57	63	217	233	145	155	38	82
70	251	199	170	130	51	69	191	259	128	172	34	86
60	216	234	147	153	45	75	165	285	111	189	30	90
50	181	269	124	177	39	82	139	312	94	207	27	94
40	146	304	100	200	32	88	112	338	76	224	23	97
30	111	339	77	223	26	94	86	364	59	241	19	101
OFF	0	450	0	300	0	120	0	450	0	300	0	120

Note: Time A = Time C and Time B = Time D



**If the default configuration is changed, verify that the installed nozzle is suitable for the new settings.**

**5.5.4.2 DPD** –The DPD cycle (DewPoint Demand) is used to adapt the cycle times, that is the quantity of air needed for the regeneration, to the real load applied to the dryer. It is necessary to install a DewPoint meter (PDP Meter - optional) to achieve this.

Set the DIP D3 on ON and the DIP D7 on ON. The DPD mode can be selected only for DewPoints of -4°F (-20°C) or -40°F (-40°C) (set the requested condition on DIP D1 and DIP D2).

After the first four operating cycles following machine start-up, run in FIX mode, the DDC15 device starts operating in DPD mode according to the following diagram:

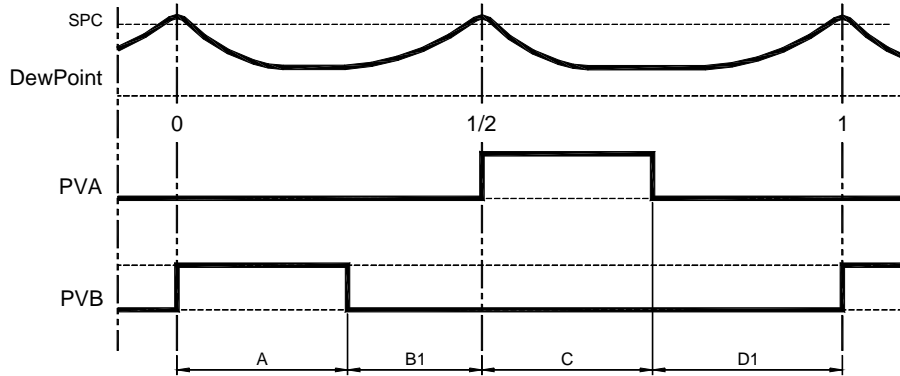

- A = Regeneration time of tower A (fixed)
- B1 = Re-pressurization time/stand-by tower A (variable)
- C = Regeneration time of tower B (fixed)
- D1 = Re-pressurization time/stand-by tower B (variable)
- SPC = Switching Set-Point (-4°F or -40°F / -20°C or -40° C)
- A = C
- B1 can be different from D1
- A + B1 + C + D1 = Complete cycle

While tower A is operating, tower B is regenerated for the set time C (fixed), determined by the selected operating cycle (see the table of the programmed values below). At the end of the regeneration phase, tower B is re-pressurized and kept in stand-by until the DewPoint meter (PDP Meter) indicates that the nominal value has been reached in the tower (SPC) and activates the DDC15 device for the switching of the towers. The process is repeated in the same way when tower B is operating.

	Low pressure 150 psig		High pressure 230 psig	
	-4°F / -20°C	-40°F / -40°C	-4°F / -20°C	-40°F / -40°C
<b>Time A = C [s]</b>	355	240	270	180
<b>Minimum value Time B1 and D1 [s]</b>	95	60	180	120

Even if the DewPoint found is lower that the set SPC value; the towers switch every 30 minutes. If the applied load is close to the nominal load, the DDC15 device automatically moves to FIX mode (the LED OFIX shows that this mode has been enabled, and it remains on together with the LED ODPD), and returns to DPD mode when the DewPoint values drop again below the SPC value.



**To better control the DPD cycle, the DewPoint value is calculated in the middle section of each tower. Of course the measured value is higher than the DewPoint at the outlet of the dryer.**



**In case of defects and/or troubles with the PDP Meter, the DDC15 device automatically enters FIX mode.**

**5.5.4.3 FIX - 2ND LOAD** – The DDC15 device allows for the management of a further load condition, through the digital input “2nd Load” on the electronic board; the value of the parameter “2nd Load” is enabled by closing a clean electric contact (volt free).

This function can be activated only in FIX mode and it can be used to control the intermittent operation of just one compressor, or a second compressor installed upstream of the dryer.

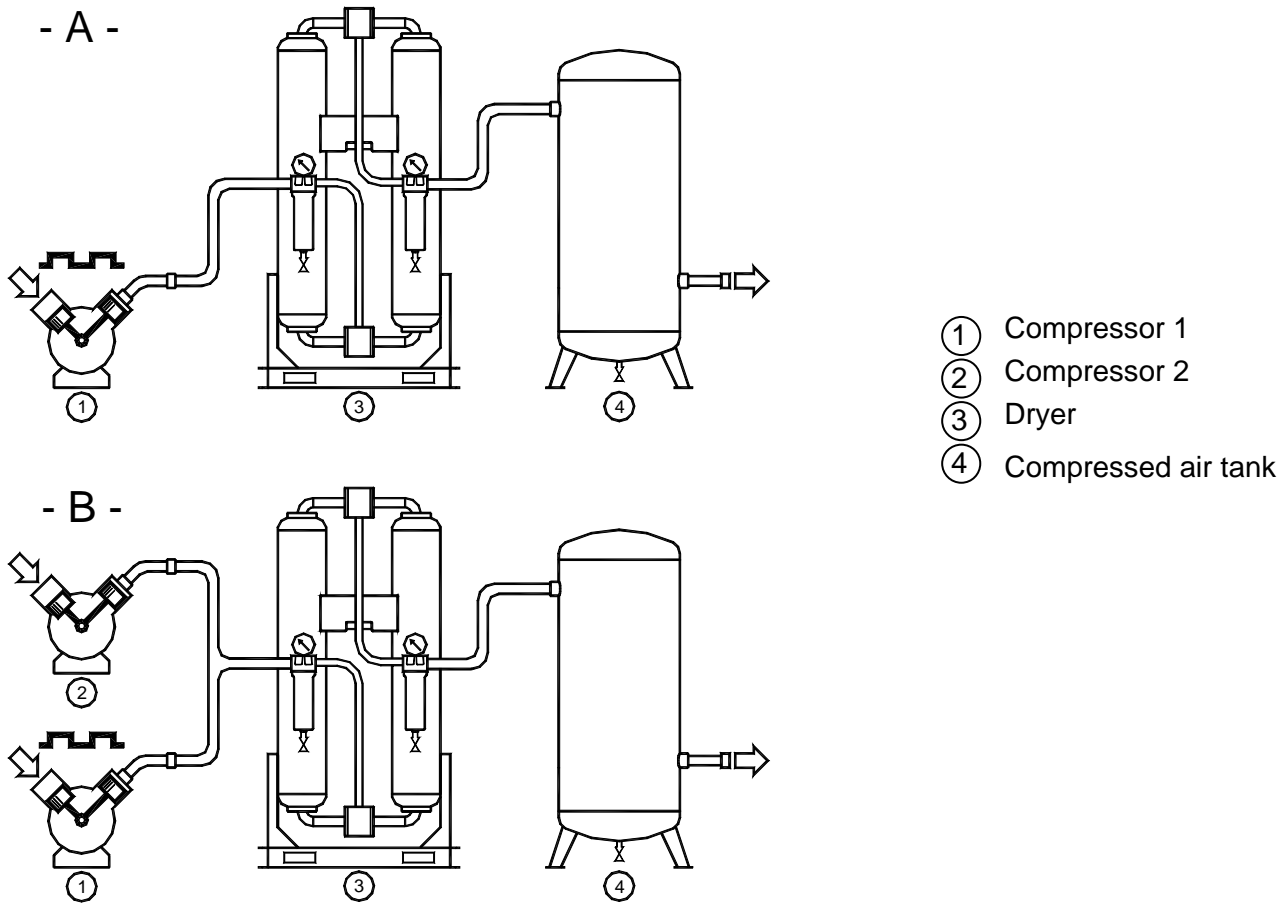

**Type -A-** installation (just one intermittent compressor), two different load conditions can be set, one matches the load actually applied and the second is set for the lack of load – OFF. Therefore, as soon as the compressor switches off, the dryer stops the last operating cycle and afterwards it moves into stand-by position.

**Type -B-** installation (two compressor installed upstream of the dryer), the first load condition is kept for the sum of the loads of the two compressors, whereas the second is used for the operation of the system with just one active compressor (for example compressor 1). To calculate the actual % of load applied, both of the “1st Load” and “2nd Load” refer to paragraph 5.5.2.1, first using the real load sum of the loads of the two compressors and then the real load of compressor 1 only.





**The connection and the set-up of the loads in the “2nd Load” mode must be carried out by qualified personnel only. If the load % is too low, the desiccant material would deteriorate quickly because it would be regenerated for shorter periods of time. The manufacturer cannot be held responsible for malfunctioning if the operating parameters have been set incorrectly.**







**5.5.4.4 TEST** – The dryer can operate following a diagnostic cycle, with step-by-step operation, to make troubleshooting or ordinary maintenance interventions easier.

Through this operating cycle the dryer runs the nine phases (from step 1 to step 9) that form the entire operating cycle.

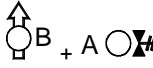
To access the TEST modality first set the relating DIP-SWITCHES (DIP D1 and DIP D2) to position ON; this condition will be displayed by the flashing “O TEST” LED on the “Cycle mode” menu of the instrument.

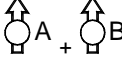
The first LED indicating the first step lights up on the DISPLAY; by pressing the  key, the dryer moves onto the following step until it reaches step 10. By pressing the key again , the dryer starts from step 1 again.

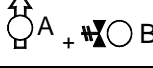
The table below shows the various steps of the dryer:

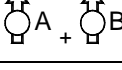
10	— 10	All the LEDs	Check operation of LEDs of DDC15 device					
9	— 9		Line pressure	Line pressure	Closed	Closed	Not powered	Not powered
8	— 8		< 5 psig < 0,3 barg	Line pressure	Open	Closed	Powered	Not powered
7	— 7		Line pressure	Line pressure	Closed	Closed	Not powered	Not powered
6	— 6		Line pressure	Line pressure	Closed	Closed	Not powered	Not powered
5	— 5		Line pressure	Line pressure	Closed	Closed	Not powered	Not powered
4	— 4		Line pressure	< 5 psig < 0,3 barg	Closed	Open	Not powered	Powered
3	— 3		Line pressure	Line pressure	Closed	Closed	Not powered	Not powered
2	— 2		Line pressure	Line pressure	Closed	Closed	Not powered	Not powered
1	— 1	No LED	Start diagnostic cycle					
STEP	LED On on DISPLAY	[On] Status of LED	A Status of towers	B Status of towers	PVA Breather solenoid valve	PVB Breather solenoid valve	PVA Elect. Breather coil	PVB Elect. Breather coil

**5.5.5 MAINTENANCE (SERVICE)** – The adsorption dryer requires a periodical maintenance which, in the proposed configuration, entails the replacement of the inlet and outlet filter and of the desiccant material. Through DIP D5 it is possible to choose the foreseen use of the machine: on OFF up to 3000 hours/year, on ON over 3000 hours/year.

The DDC15 device will then count the number of working hours and will engage the maintenance alarms, or better reminders, when certain values are reached. See table below:

	DIP D5 = OFF		DIP D5 = ON	
	Alarm	Following reminder	Alarm	Following reminder
Filter IN	Every 3000 hours	Every 600 hours	Every 4000 hours	Every 800 hours
Filter OUT				
Desiccant material	Every 9000 hours	Every 1000 hours	Every 12000 hours	Every 1500 hours

The maintenance alarms (reminder) do not change in any way the operation of the DDC15 device.

**5.5.6 FUSES** – Three different safety fuses are fitted on the electronic board, in positions F1, F2 and F3. the fuses protect the following circuits:

F1 = (2A type “T”  $\varnothing$ 5x20 mm) → mains;

F2 = (1A type “T”  $\varnothing$ 5x20 mm) → condensate drain solenoid valve;

F3 = (0,5A type “T”  $\varnothing$ 5x20 mm) → control logic.



**The fuses can burn if there are any problems with the dryer. In this case, replace them, after solving the problem that caused the malfunctioning. Also refer to the specific paragraph “TROUBLESHOOTING”.**

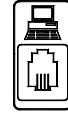

**5.5.7 SERIAL COMMUNICATION** – The DDC15 device is fitted with a serial port RJ 45 (with signal type RS 232) which allows for the connection to a network controlled by a PC (Personal Computer) or a PLC (Programmable Logic Control).

The dryer can make the following information available:

1. operating conditions.
2. operating parameters.
3. Alarms.
4. Time remaining before the next programmed maintenance intervention.



**To transfer the information above, no interface hardware is necessary. Simply ask your distributor/dealer for a dedicated software able to read these parameters.**

If you wish to permanently connect the dryer to a monitoring network, there is also a 2 pole connector on the electronic board of the device (see illustration below) which can be connected through a bi-polar cable to the PC or the PLC.



**Only qualified personnel must carry out the interventions for the serial connection of the dryer. Before any intervention make sure that:**

- **No parts of the machine are under voltage** and that is cannot be re-connected to the mains.

### 5.6 DEWPOINT METER - (OPTIONAL)

The DDC15 device has an analog input 4-20mA which the DewPoint meter is connected to (PDP Meter) and a sampling system.

By installing the DewPoint meter it is possible to :

- show the DewPoint value on the display of the DDC15 device;
- enable the operation of the dryer in DPD mode (see paragraph 5.5.4.2 DPD);
- enable the HI PDP alarm (see paragraph 5.5.3.2 DIP-SWITCHES).

The sampling system includes a cell (Pos. 2) which holds the DewPoint meter's sensor (PDP Meter). A constant flow of compressed air must flow through the cell (about 2 liters/minute), taken from the operating tower. The selector valve (Pos. 1) is used to choose the operating tower from which to take the air to be measured. The quantity is controlled by the air flow adjuster (Pos. 3).

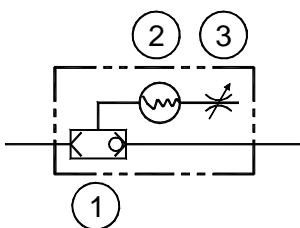

- ① Working tower selector valve
- ② Sampling cell with DewPoint meter
- ③ Air flow adjuster

**5.6.1 PDP ANALOG SIGNAL**– In the standard installation, the analog signal supplied by the PDP translator is used only by the DDC15 instrument. The user has the possibility to use the analog signal 4-20mA for any other operation (such as the monitoring of the humidity level, etc).

Hence, just simply put the mA meter on terminal S of the DDC15 device, as shown in the following illustration. The signal variation ranges between 4mA (-112°F / -80°C) and 20mA (68°F / +20°C), whereas the measurement range of the device is reliable in the interval between -76°F (-60°C) and 68°F (+20°C) .

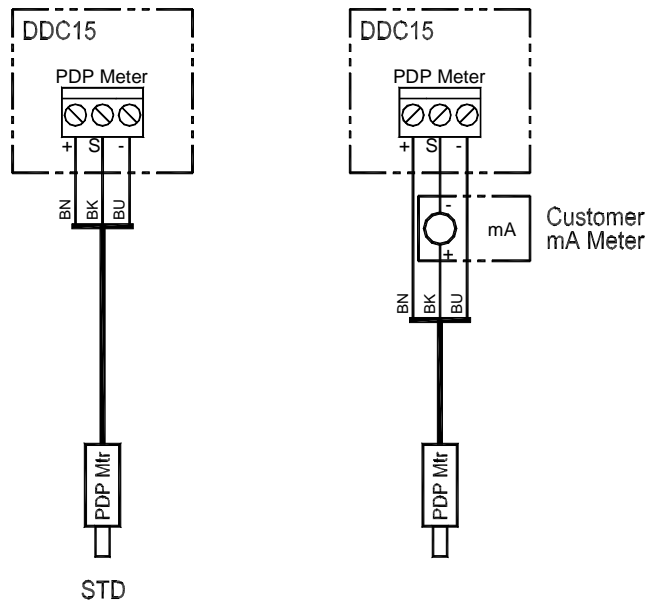

**5.7 PRESSURE SWITCHES OF “FAIL TO SWITCH ALARM” - (OPTIONAL)**

A pressure switch is installed on each tower (PSA and PSB respectively) to enable the “FAIL TO SWITCH ALARM” function of the DDC15 device. The PSA pressure switch is closed when tower A is under pressure and PSB is closed when tower B is under pressure.

The system is able to detect an alarm condition if, for any reason, the flow between the two towers was not switched or the switching was not done correctly.

The “Fail to Switch alarm” function is enabled by positioning the DIP U2 on ON (also refer to paragraph 5.5.3.2 “DIP-SWITCHES”).

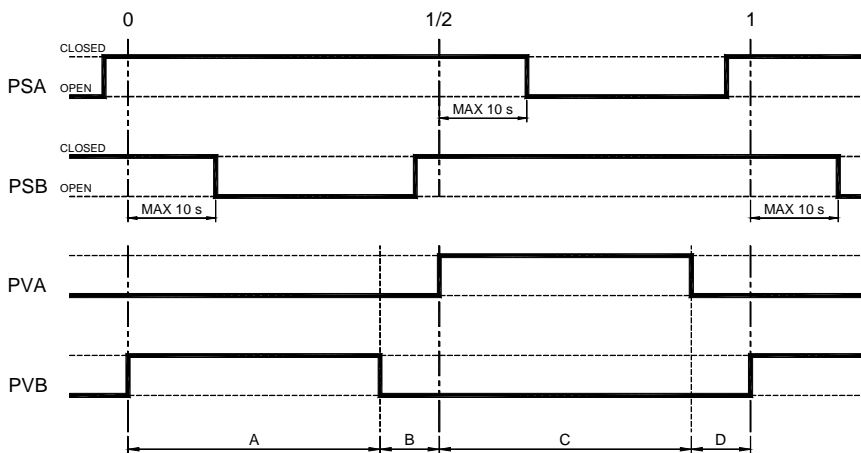

- Point 0 : PSA must already be closed, whereas PSB must open in a maximum time of 10 seconds.
- Point 1/2 : PSB must already be closed whereas PSA must open in a maximum time of 10 seconds.
- Point 1 = Point 0 (the cycles are repetitive) .

**5.7.1 CALIBRATION PRESSURES** – The calibration values of the pressure switches are indicated below:

Dryer operating pressure :		Pressure switch closing pressure :		Pressure switch opening pressure :	
[psig]	[barg]	[psig]	[barg]	[psig]	[barg]
58 - 86	4 - 5,9	≥ 43,5	≥ 3	≤ 14,5	≤ 1
87 - 129	6 - 8,9	≥ 58	≥ 4	≤ 14,5	≤ 1
130 - 173	9 - 11,9	≥ 87	≥ 6	≤ 14,5	≤ 1
> 174	> 12	≥ 116	≥ 8	≤ 14,5	≤ 1

## 6.1 CONTROLS AND MAINTENANCE



The maintenance operations must be worked out by qualified personnel.

**Before any intervention, verify that:**



- **no part of the machine is powered** and that it cannot be connected to the mains supply.
- **no part of the machine is under pressure** and that it cannot be connected to the compressed air system.



The user that intervenes to the machine must wear hearing protection before to operate into the dryer. Each employee must select proper PPD (Personal Protection Device) hearing protector (earmuffs, ear canal caps and earplugs) in order to prevent any uneasiness that could cause dangerous situation for him.



### DAILY

- Check if the inlet filter condensate drain works regularly.
- Check the clogging state of the filters by reading the differential pressure gauge installed.
- Check that the tower switching operation takes place correctly and in the set cycle times.
- Check that the differential pressure gauge, of the regenerating tower, indicates 0 bar.



### YEARLY – 3000 HOURS

- Replace the inlet and outlet filter cartridge.
- Clean the silencers or if necessary replace them.
- Check if the regeneration drain solenoid valves (PVA e PVB) work regularly.
- Check if all screws of the electrical wiring are correctly tightened.
- After the checking operating, control the working of the dryer.



### EVERY 2 YEARS – 6000 HOURS

In addition to the programmed maintenance, every year:

- Replace the membrane of the regeneration drain solenoid valves (PVA and PVB).
- Replace the techno-polymer of the shuttle spool valves.
- After the control operation, control the working of the dryer.



### EVERY 3 YEARS – 9000 HOURS

- Replace the adsorption material.

The estimated average life of the adsorption material is 3-5 years, with 10-minute cycle times and 3000 hours/year in any case it depends on the quality and temperature of the inlet air and on the correct programmed maintenance.

## 6.2 TROUBLESHOOTING



The troubleshooting and the eventual checks have to be performed by qualified personnel. **We suggest enabling the TEST modality to make troubleshooting operations easier (see paragraph 5.5.4.4) and gradually verify that the operating steps are performed correctly.**











The user that intervenes to the machine must wear hearing protection before to operate into the dryer. Each employee must select proper PPD (Personal Protection Device) hearing protector ( earmuffs, ear canal caps and earplugs) in order to prevent any uneasiness that could cause dangerous situation for him.

### PROBLEM

### POSSIBLE CAUSE - SUGGESTED ACTION

- ◆ Humidity in outlet air.
  - ⇒ The dryer is off - switch it on.
  - ⇒ The dryer has just been started up and the adsorption material can contain humidity – use the dryer at a reduced nominal flow of 50% for at least 2 days and verify the correct operation of the machine.
  - ⇒ The dryer don't perform the switching cycles – see specific paragraph.
  - ⇒ The inlet air is too hot - restore the nominal conditions.
  - ⇒ The inlet air pressure is too low – verify that the installed regeneration nozzle is for the real working pressure of the dryer. If you have doubts or problems, please contact your distributor.
  - ⇒ The inlet air flow rate is higher than the rate of the dryer - reduce the flow rate - restore the nominal conditions.
  - ⇒ Inlet filter does not drain the condensate – check the proper operation of the drainer.
  - ⇒ Electronic timer of the inlet filter drainer is not adjusted correctly – reduce the drain pause time.
  - ⇒ The pressure gauge of the tower under regeneration shows a pressure higher than 0 – silencers are clogged – clean or replace them.
  - ⇒ Cycle time on DDC15 Electronic Controller has been modified – restore the nominal times.
  - ⇒ Desiccant material is exhausted - replace.
- ◆ Solenoid valve PVA and/or PVB are never activated.
  - ⇒ Check for mains failure.
  - ⇒ Verify the electric wiring.
  - ⇒ Verify fuses on DDC15 Electronic Controller.
  - ⇒ The valve is blocked – open and clean it.
  - ⇒ The coil of the solenoid valve burned out - replace it.
- ◆ Dryer does not perform the switching cycles.
  - ⇒ Solenoid valve PVA and/or PVB are never activated - see specific point.
  - ⇒ Inlet and/or outlet shuttle spool valve is blocked – carry out maintenance operations.
- ◆ All the inlet air is discharged through the silencers.
  - ⇒ The dryer does not perform the switching cycles - see specific point.
  - ⇒ The solenoid valve PVA and/or PVB is blocked – open and clean it.
  - ⇒ The membrane of solenoid valve PVA and/or PVB is broken – carry out maintenance operations.
  - ⇒ The DDC15 Electronic controller always supplies solenoid valve PVA and/or PVB – verify the electric wiring and if necessary replace.
  - ⇒ The cycle times on the DDC15 electronic controller have been changed – restore nominal conditions.
  - ⇒ Regeneration nozzle is clogged – open and clean it.
- ◆ Liquid comes out of the silencers.
  - ⇒ Humidity in outlet air – see specific paragraph.

- ◆ LED  ○ “HI PDP” of the DDC15 device flashes or is on. ⇒ The probe of the DewPoint Meter (optional) detects a high DewPoint, for one of the following reasons:
  1. Humidity at dryer outlet – see specific paragraph.
  2. The air flow adjuster setting has been changed (see paragraph 5.6) – reset nominal value.
  3. The selector valve of the operating tower (see paragraph 5.6) is blocked – replace it.
  4. Verify the electric connection of the probe.
  5. The probe is not calibrated – contact the dealer.
  6. The probe is broken – replace it.
  7. There is an air leak on the pipes and/or joints that connect the equipment – verify the connections and replace the damaged parts.
  8. A pipe or a joint which connects the equipment is clogged – replace it.
  
- ◆ The LED  ○ “FAIL TO SWITCH” of the DDC15 device flashes or is on. ⇒ The pressure switches (optional) for the “FAIL TO SWITCH” function, show an anomalous conditions during the tower switching process, for one of the following reasons:
  1. The dryer does not run the switching cycle – see specific paragraph.
  2. All the inlet air is purged through the silencers – see specific paragraph.
  3. The solenoid valve PVA and/or PVB is never enabled – see specific paragraph.
  4. The pressure switches are not calibrated – reset the default settings (see paragraph 5.7).
  5. There is an air leak on the pipes and/or joints that connect the equipment – verify the connections and replace the damaged parts.
  6. A pipe or a joint which connects the equipment is clogged – replace it.
  
- ◆ The LED  ○ “SERVICE” of the DDC15 device flashes or is on. ⇒ The dryer needs maintenance (also refer to paragraphs 5.5.1 “SYNOPTIC PANEL” and 6.3 “CONTROLS AND MAINTENANCE”), more precisely :
  1. If the LED “SERVICE” flashes together with the LED , it means that the inlet filter of the dryer is clogged – replace the filtering element (cartridge).
  2. If the LED “SERVICE” flashes together with the LED , it means that the outlet filter of the dryer is clogged – replace the filtering element (cartridge).
  3. If the LED “SERVICE” flashes together with both LEDs  -  the filter programmed maintenance timer went off – replace the filtering elements (cartridges).
  4. If the LED “SERVICE” flashes together with both LEDs  A -  B the adsorbent material programmed maintenance timer went off – replace the desiccant bed.

### 6.3 SUGGESTED SPARE PARTS

The suggested spare parts list will enable you to promptly change any defected parts without having to wait for the spare parts to be delivered. If you need to replace any other parts, you need to contact a technician or have the part serviced in our factory.

ID.	SPARE PART DESCRIPTION	CODE	170	210	250	300	420	540	680	850
9 to 14	Shuttle valve kit <sup>(1)</sup>	2218SPL051	1♦	1♦						
	Shuttle valve kit <sup>(1)</sup>	2218SPL075			1♦	1♦				
	Shuttle valve kit <sup>(1)</sup>	2218SPL130					1♦	1♦		
	Shuttle valve kit <sup>(1)</sup>	2218SPL200							1♦	1♦
3	Desiccant material kit 175 lbs / 79kg <sup>(2)</sup>	2221DMK050	1♦							
	Desiccant material kit 215 lbs / 98kg <sup>(2)</sup>	2221DMK060		1♦						
	Desiccant material kit 260 lbs / 118kg <sup>(2)</sup>	2221DMK075			1♦					
	Desiccant material kit 310 lbs / 140kg <sup>(2)</sup>	2221DMK090				1♦				
	Desiccant material kit 430 lbs / 195kg <sup>(2)</sup>	2221DMK130					1♦			
	Desiccant material kit 550 lbs / 250kg <sup>(2)</sup>	2221DMK160						1♦		
	Desiccant material kit 705 lbs / 320kg <sup>(2)</sup>	2221DMK200							1♦	
	Desiccant material kit 870 lbs / 395kg <sup>(2)</sup>	2221DMK250								1♦
9 to 14	Complete shuttle valve <sup>(3)</sup>	64360FF516	2	2						
	Complete shuttle valve <sup>(3)</sup>	64360FF520			2	2				
	Complete shuttle valve <sup>(3)</sup>	64360FF525					2	2		
	Complete shuttle valve <sup>(3)</sup>	64360FF530							2	2
16	Tower pressure gauge	5660NNN052	2	2	2	2	2	2	2	2
17	Orifice 3/8" (to be drilled into the right size)	62OT118002	1	1	1	1				
	Orifice 1/2" (to be drilled into the right size)	62OT118003					1	1	1	1
18	Complete diaphragm valve w/coil	64N20FF070	2	2						
	Complete diaphragm valve w/coil	64N20FF075			2	2				
	Complete diaphragm valve w/coil	64N20FF080					2	2		
	Complete diaphragm valve w/coil	64N20FF085							2	2
18	Diaphragm valve Kit	64N20FF120	2♦	2♦	2♦	2♦				
	Diaphragm valve Kit	64N20FF130					2♦	2♦	2♦	2♦
18	Diaphragm valve coil	64N22FF010	2	2	2	2	2	2	2	2
19	Silencer	64N56MN100	2	2	2	2	3	4	6	8
23	Inlet cartridge 0,01 micron	E821XA	1♦	1♦	1♦					
	Inlet cartridge 0,01 micron	E831XA				1♦	1♦			
	Inlet cartridge 0,01 micron	E851XA						1♦		
	Inlet cartridge 0,01 micron	E1251XA							1♦	1♦
24	Outlet Cartridge dust removal 1 micron	E821X1	1♦	1♦	1♦					
	Outlet Cartridge dust removal 1 micron	E831X1				1♦	1♦			
	Outlet Cartridge dust removal 1 micron	E851X1						1♦		
	Outlet Cartridge dust removal 1 micron	E1251X1							1♦	1♦
25	Filter Delta P gauge	DPS	2	2	2	2	2	2	2	2
-	Control panel DCC15	5620150005	1	1	1	1	1	1	1	1

(1) : include shuttle spool, o-rings and gasket

(2) : include desiccant material and diffuser segger rings

(3) : include shuttle body, spool, o-rings, gaskets and special screws & nuts

#### ♦ Recommended spare parts.

**NOTE :** To order the recommended spare parts or any other part always indicate the data on the identification plate.

## 6.4 DISMANTLING OF THE DRYER

If the dryer is to be dismantled, it has to be split into homogeneous groups of materials.



Part	Material
Desiccant material	Molecular sieve, Oil
Frame and supports	Carbon steel, Epoxy paint
Piping	Aluminum, Carbon steel, Epoxy paint
Towers and diffuser	Carbon steel, Stainless steel, Epoxy paint
Shuttle spool valve	Stainless steel AISI 316L, Techno-polymer
Filter housing	Aluminum, Epoxy paint
Filter cartridge	Filtering material, PVC, Oil
Solenoid valve	Bronze, Steel, Techno-polymer, PVC
Condensate Drain	PVC, Aluminum, Steel, Bronze
Silencers	Aluminum, Stainless Steel
Safety Valves	Brass
Gaskets and O-Ring	Graphite, synthetic elastomer
Electric cables	Copper, PVC
Electric Parts	PVC, Copper, Bronze



We recommend to comply with the safety rules in force for the disposal of each type of material. The adsorption material and the filter cartridge contains droplets of lubrication oil. Do not dispose these materials in the environment. Delivered it to a collection centre.

### 7.1 DRYER DIMENSIONS

#### 7.1.1 HDT 170 to 850 U

### 7.2 EXPLODED DRAWINGS

#### 7.2.1 Exploded view models HDT170 to 850 U

##### Table of components exploded view

① Frame	⑪ Shuttle valve – Spool	⑲ Silencer
② Tower	⑫ Shuttle valve – OR	⑳ Pipe air IN
③ Desiccant material	⑬ Shuttle valve – OR	㉑ Pipe air OUT
④ Diffuser	(HDT 250 to 850 U)	㉒ Filter – Body
⑤ Ring – Seger (HDT 250 to 850 U)	⑭ Valve flange gasket (HDT 250 to 850 U)	㉓ Filter – Element XA (0,01 micron)
⑥ Pressure relief valve	⑮ Tower flange gasket (HDT 250 to 850 U)	㉔ Filter – Element X1 (Dust removal 1 micron)
⑦ Reducer x safety valve	⑯ Tower gauge	㉕ Filter DeltaP gauge
⑧ Cap	⑰ Orifice	㉖ Manual Drain
⑨ Shuttle valve – Body	⑱ Diaphragm solenoid valve	㉗ Drain
⑩ Shuttle valve – flange		

## 7.3 WIRING

### 7.3.1 Wiring diagram

#### *Wiring components*

<b>DDC 15</b>	: Electronic control device
<b>Main Card</b>	: Main board
<b>Display Card</b>	: Display module of electronic board
<b>PWR</b>	: Supply power
<b>FDV</b>	: Inlet filter drain
<b>FT IN</b>	: Inlet filter Delta-P gauge/pressure switch
<b>FT OUT</b>	: Outlet filter Delta-P gauge/pressure switch
<b>PSA</b>	: Tower A pressure switch
<b>PSB</b>	: Tower B pressure switch
<b>2nd Load</b>	: Second load Activation (MUST BE USED A VOLT FREE CONTACT)
<b>PDP Meter</b>	: DewPoint meter
<b>ALARM</b>	: Volt free contact for alarm signal
<b>PVA</b>	: Tower A regeneration valve
<b>PVB</b>	: Tower B regeneration valve
<b>DIPS U</b>	: Set-Up Dip-Switch series U
<b>DIPS D</b>	: Set-Up Dip-Switch series D

BN = BROWN

BU = BLUE

BK = BLACK

### 7.1.1 HDT 170 to 850 U

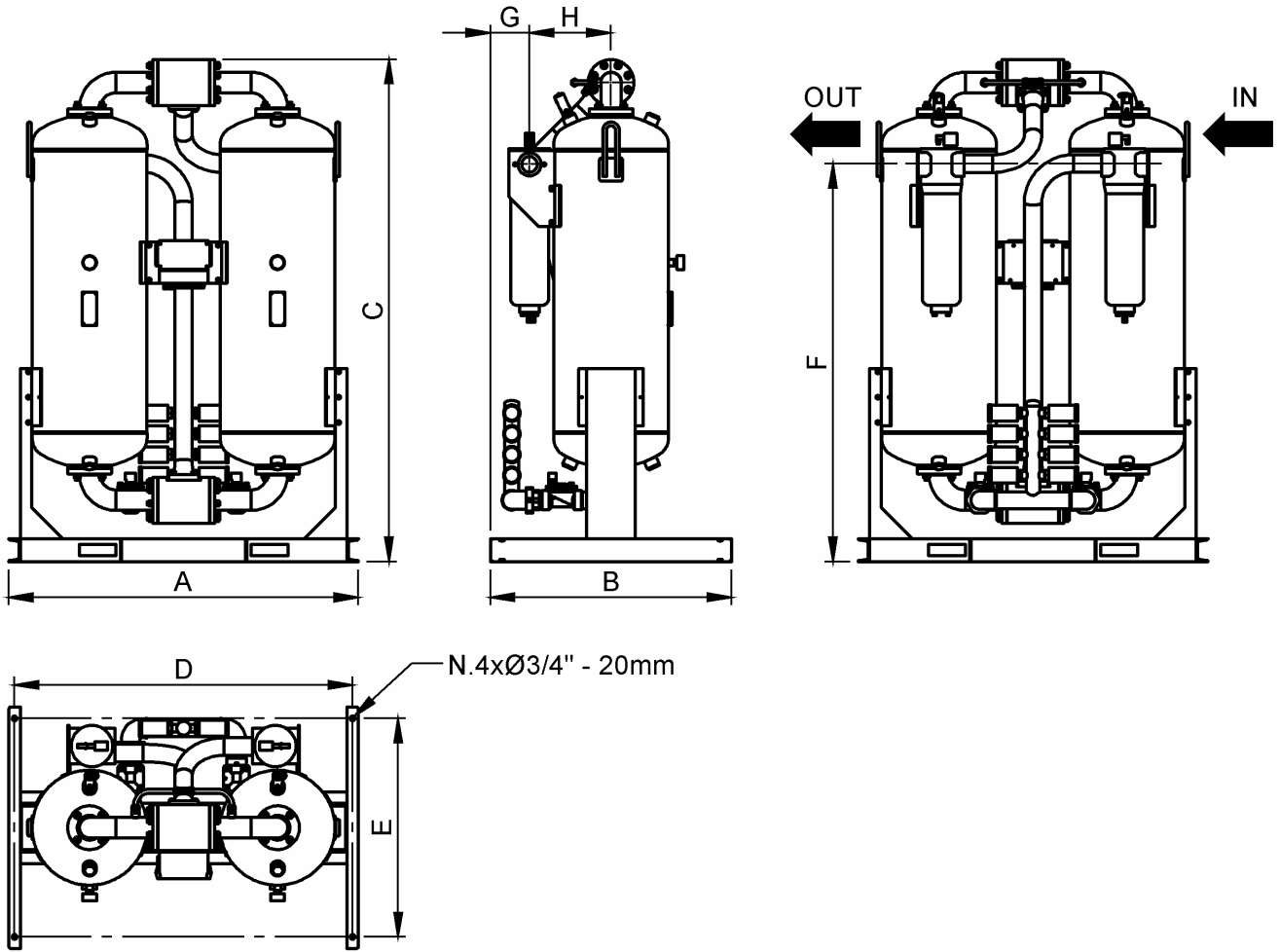

		A	B	C	D	E	F	G	H
HDT 170U	mm inch	1005 39.1/2	700 27.1/2	2155 85	955 37.1/2	600 23.1/2	1140 45	135 5.1/2	215 8.1/2
HDT 210U	mm inch	1030 40.1/2	700 27.1/2	2165 85.1/8	980 38.1/2	600 23.1/2	1140 45	120 4.3/4	230 9
HDT 250U	mm inch	1060 41.3/4	700 27.1/2	2000 78.3/4	1010 39.3/4	600 23.1/2	1080 42.1/2	125 5	225 8.3/4
HDT 300U	mm inch	1100 43.1/4	700 27.1/2	2000 78.3/4	1050 41.3/8	600 23.1/2	1070 42.1/4	105 4.1/4	245 9.3/4
HDT 420U	mm inch	1250 49.1/4	870 34.1/4	2090 82.1/4	1200 47.1/4	770 30.3/8	1250 48.1/4	155 6.1/4	280 11
HDT 540U	mm inch	1310 51.1/2	870 34.1/4	2090 82.1/4	1260 49.1/2	770 30.3/8	1230 48.1/2	135 5.1/2	300 11.3/4
HDT 680U	mm inch	1475 58	1050 41.3/8	2170 85.3/8	1425 56	950 37.3/8	1730 68	195 7.3/4	330 13
HDT 850U	mm inch	1525 60	1050 41.3/8	2180 86	1475 58	950 37.3/8	1730 68	170 7	355 14

7.2.1 HDT 170 to 850 U

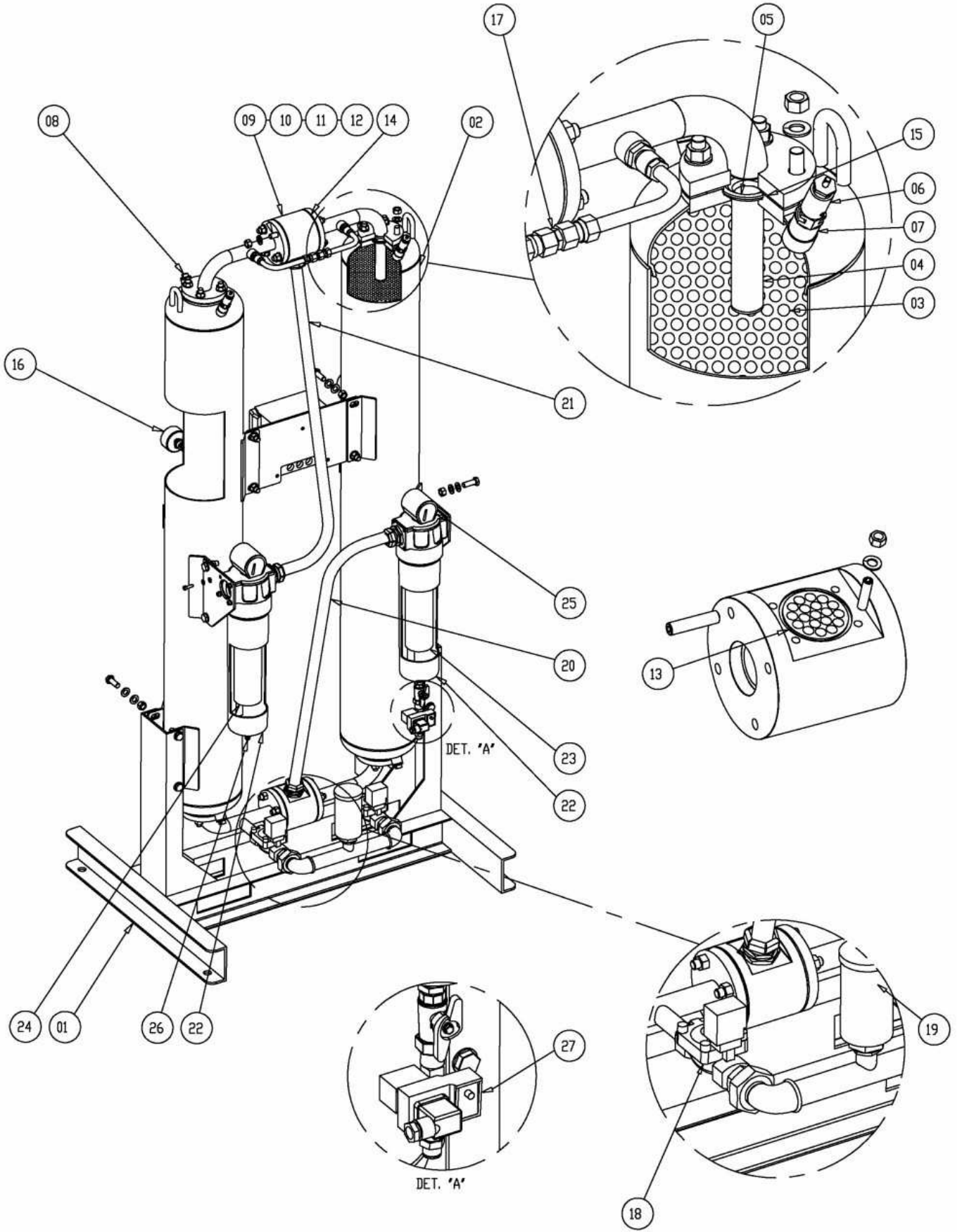

### 7.3.1 HDT 170 to 850 U

